

KIDS OUTPERFORM OXFORD TWATS AND DISCOVER QUANTUM STUFF THAT TOOK TOP SCIENTISTS 60y



Can QM be formulated in **childish pictures** ?

YES !

"Picturing Quantum Processes is a lively and refreshing romp through the author's diagrammatic and categorical approach to quantum processes. I recommend this book with no lower age limit required!"
Clark Kaufman, University of Illinois

"This book develops from scratch the category theoretic and diagrammatic language for quantum theory especially quantum processes. It is a remarkable achievement: rigorous, crystal-clear, complete and a delight to read."
Jeremy Butterfield, University of Cambridge

The unique features of the quantum world are explained in this book through the language of diagrams, setting out an innovative visual method for presenting complex theories. Requiring only basic mathematical literacy this book employs a unique formalism that builds an intuitive understanding of quantum features while eliminating the need for complex calculations. This actively diagrammatic presentation of quantum theory represents the culmination of 10 years of research, uniting classical techniques in linear algebra and Hilbert spaces with cutting-edge developments in quantum computation and foundations.

Written in an entertaining and user-friendly style and including more than 100 exercises, this book is an ideal first course in quantum theory, foundations, and computation for students from undergraduate to PhD level, as well as an opportunity for researchers from a broad range of fields, from physics to biology, linguistics, and cognitive science, to discover a new way of looking at quantum processes and interaction.

Bob Coecke is Professor of Quantum Foundations, Logic and Structures at Oxford University, where he also heads the multi-disciplinary Quantum Mechanics to the Computational Structure of Natural Language meaning and recent interests include causality and cognitive architecture.

Aleks Kissinger is an Assistant Professor of Quantum Structures and Logic at Oxford University. His research focuses on diagrammatic language, rewrite theory, category theory, and applications to quantum computation and the foundations of physics.

CAMBRIDGE
UNIVERSITY PRESS
www.cambridge.org



COECKE
AND
KISSINGER

PICTURING QUANTUM
PROCESSES

CAMBRIDGE

PICTURING QUANTUM
PROCESSES

A First Course in Quantum Theory and Diagrammatic Reasoning

BOB COECKE AND ALEKS KISSINGER



COECKE
AND
KISSINGER

PICTURING QUANTUM
PROCESSES

CAMBRIDGE

PICTURING QUANTUM PROCESSES

A First Course in Quantum Theory and Diagrammatic Reasoning

BOB COECKE AND ALEKS KISSINGER



– *processes as boxes and systems as wires* –

– processes as boxes and systems as wires –

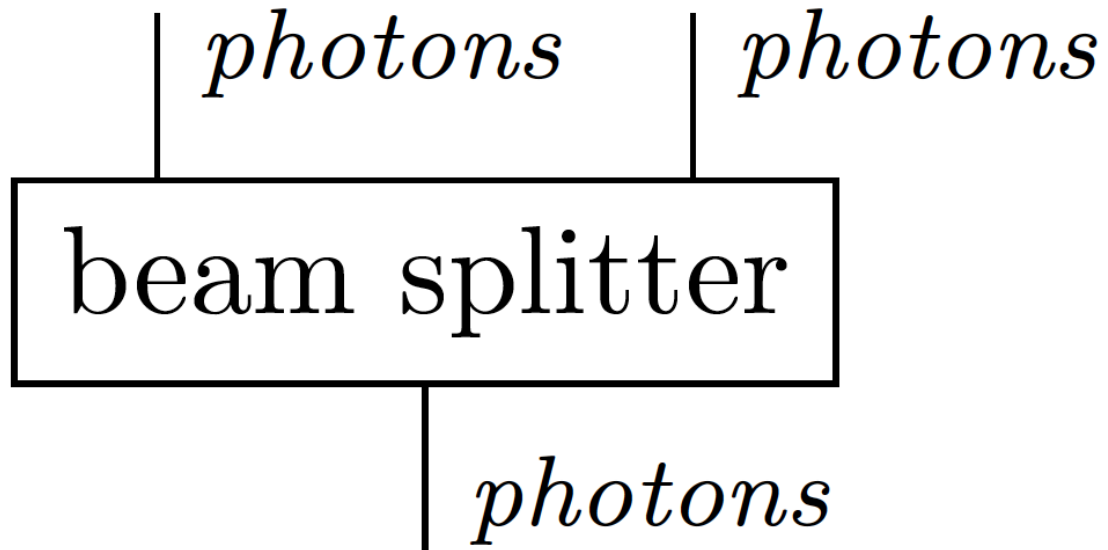

– processes as boxes and systems as wires –

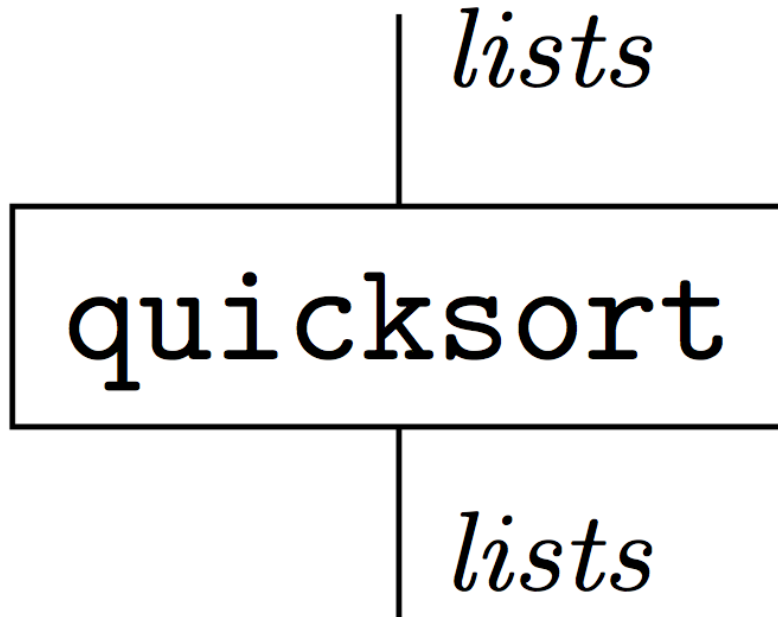

– processes as boxes and systems as wires –

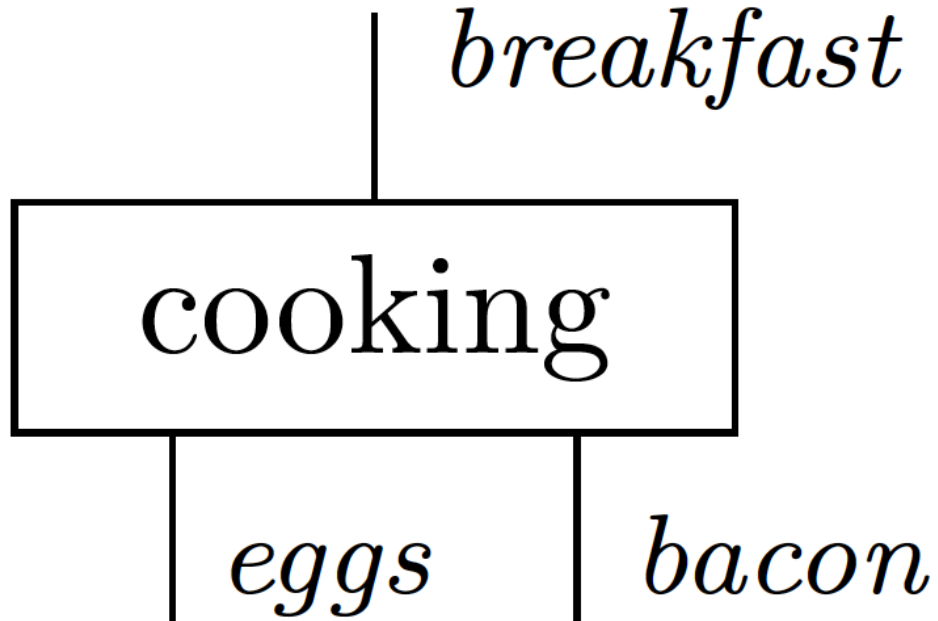

– processes as boxes and systems as wires –

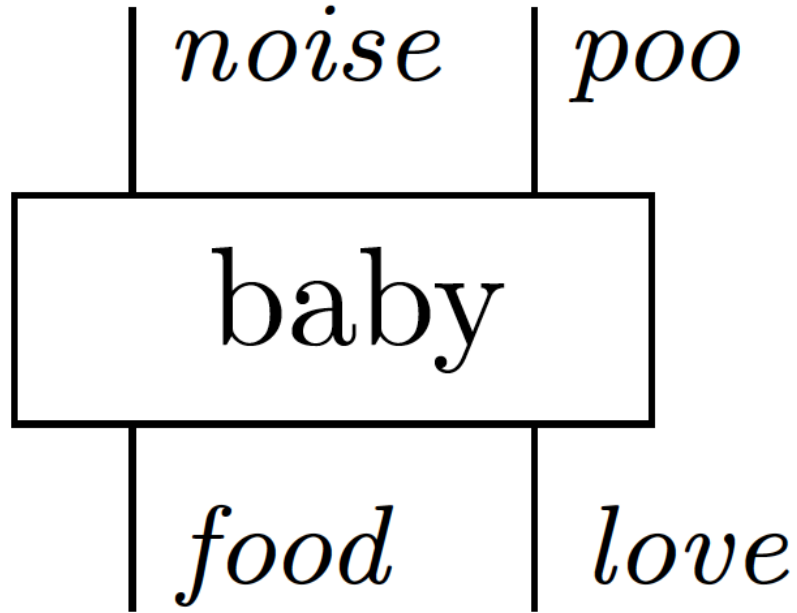

– composing processes –

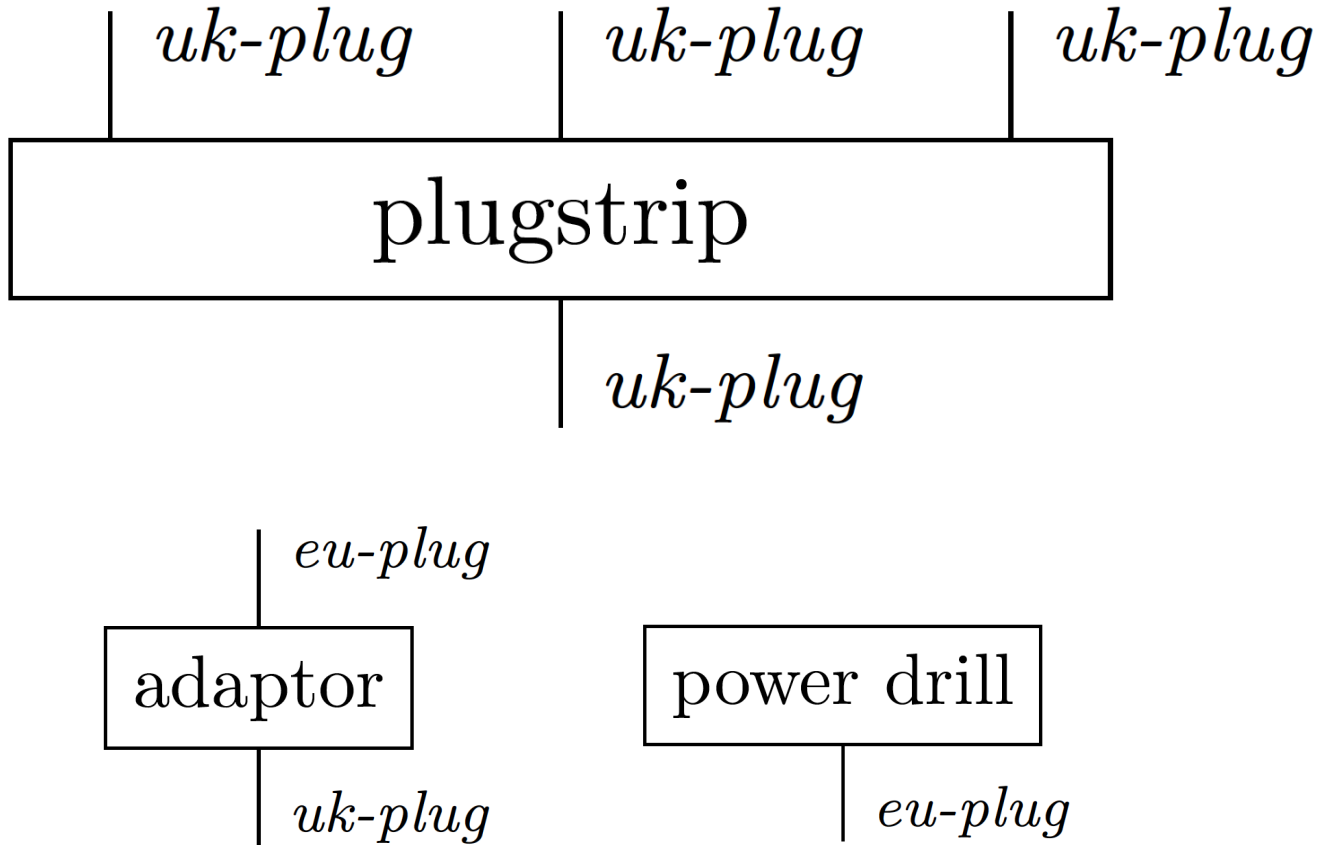

– composing processes –

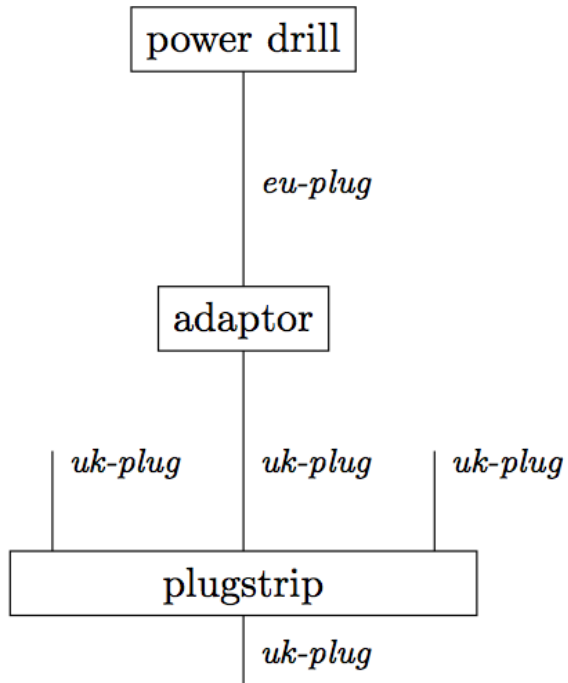

:=

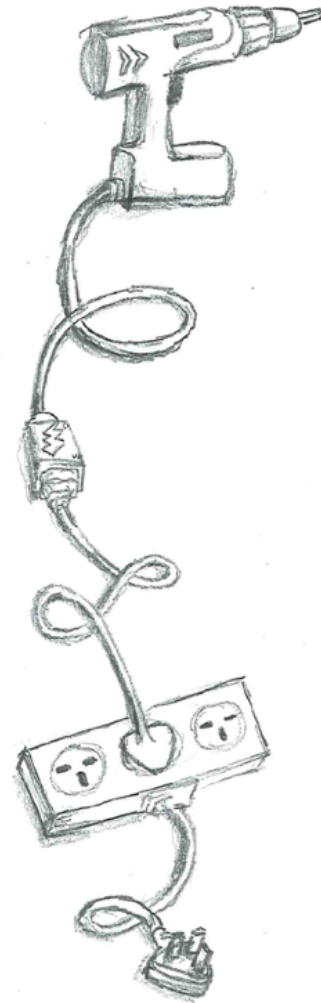

– *composing processes* –

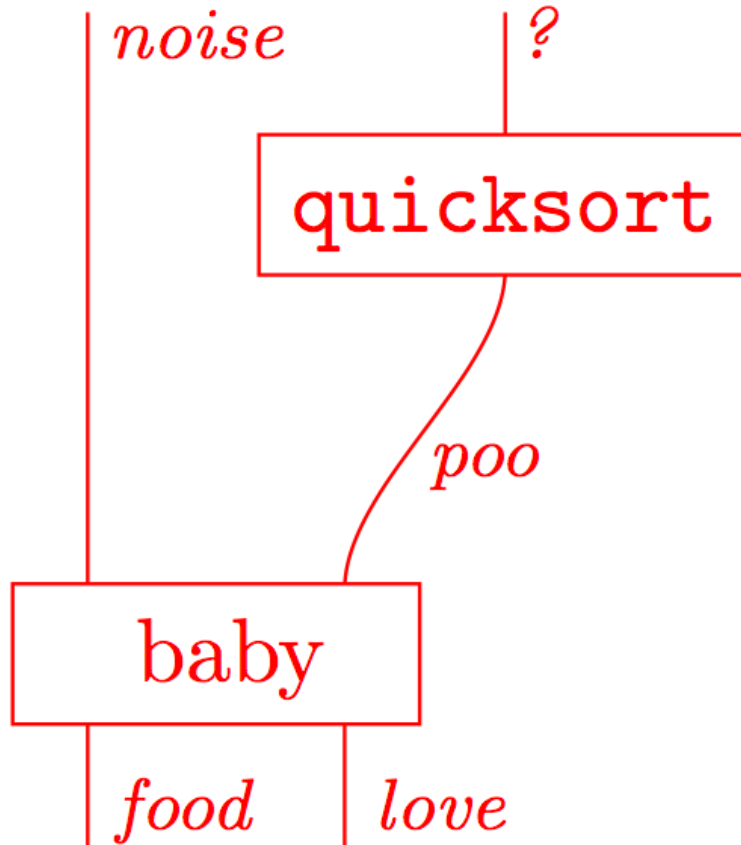

– tautologies –

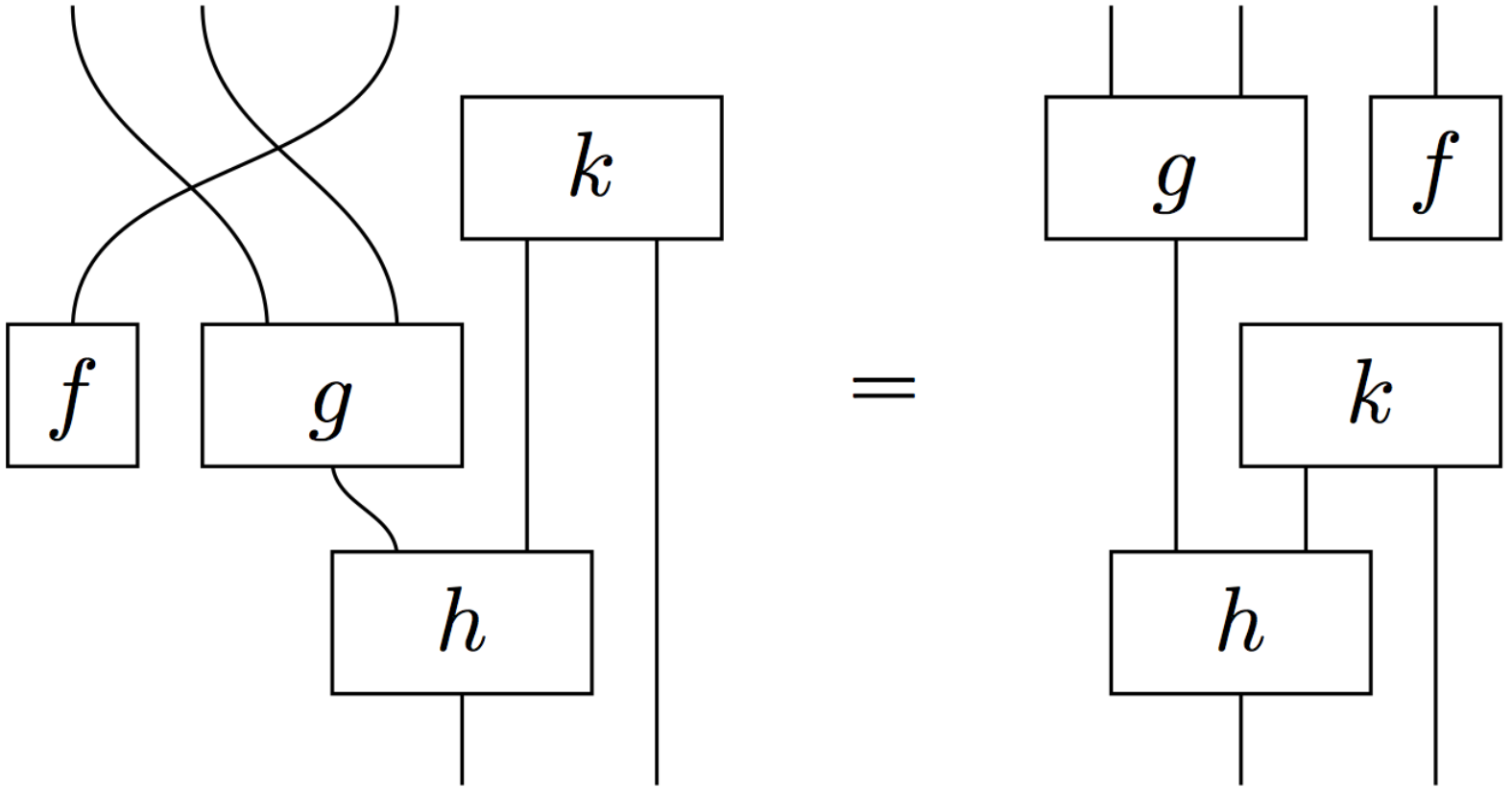

– special processes/diagrams –

State :=

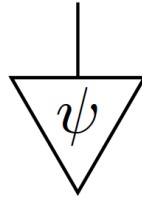

Effect / Test :=

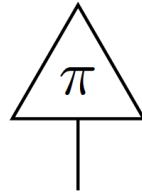

Number :=



– special processes/diagrams –

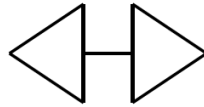
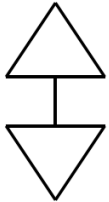
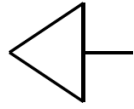
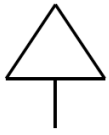
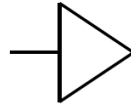
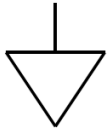

– special processes/diagrams –

Born rule :=

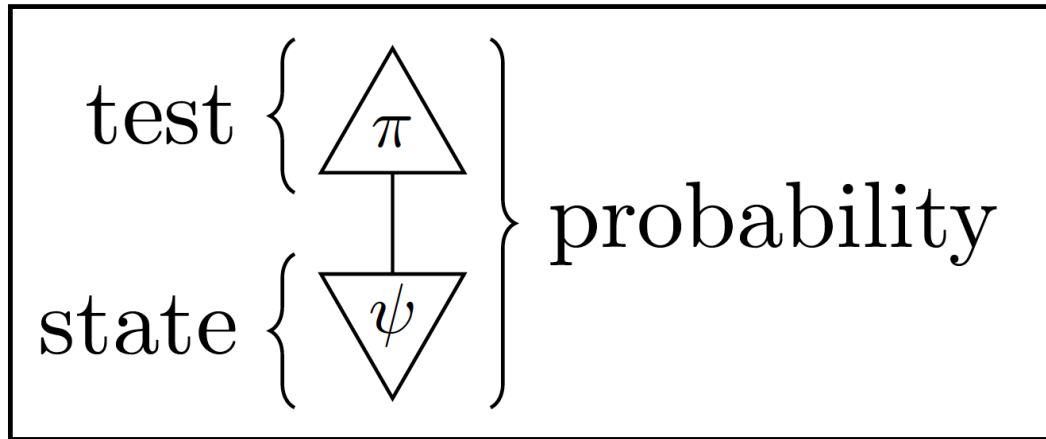

– “ $f \otimes g$ ” := “ f while g ” –

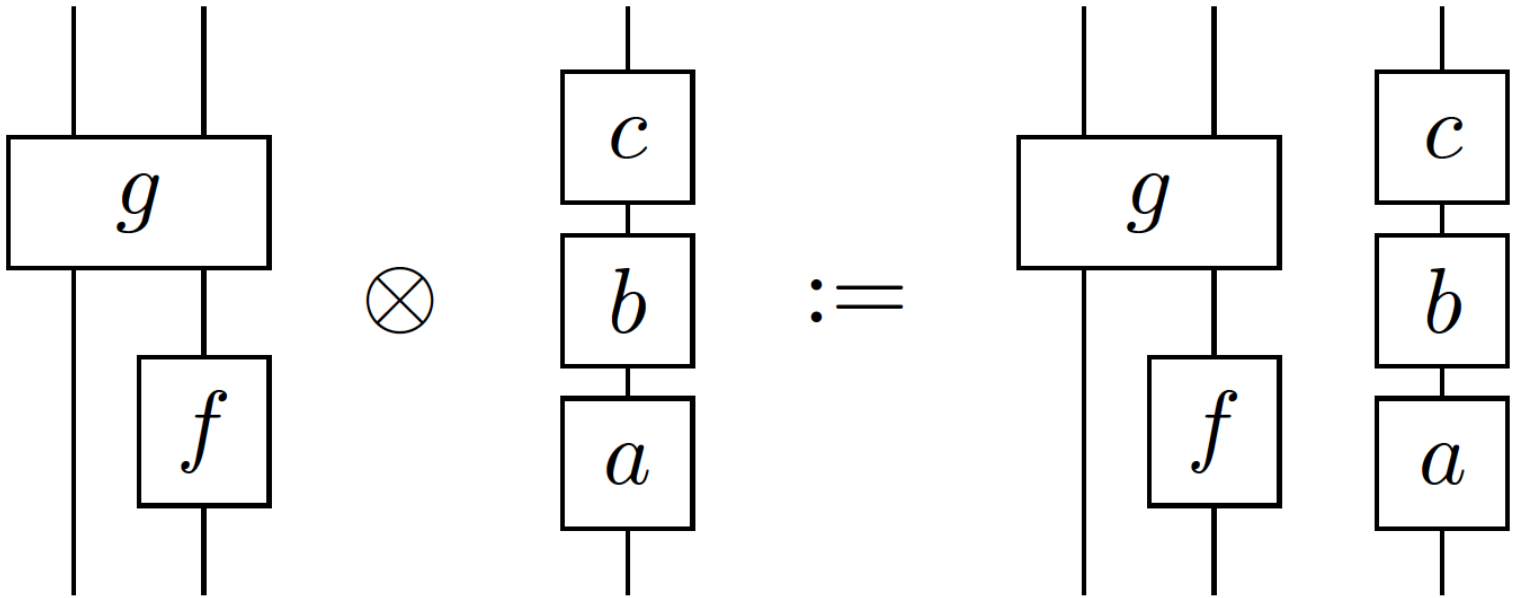

– “ $f \circ g$ ” := “ f after g ” –

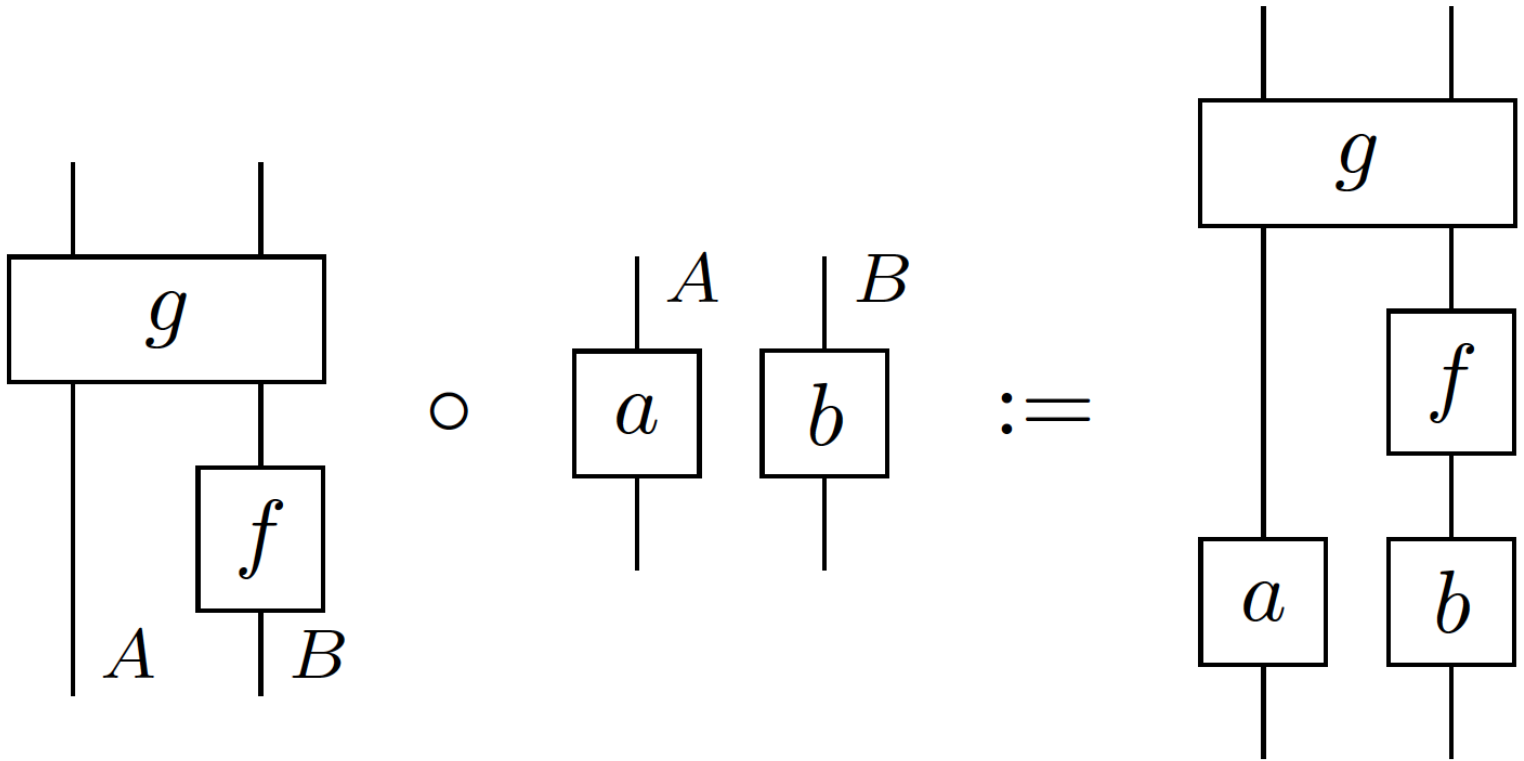

– *circuits* –

Defn. ... := can be build with \otimes and \circ .

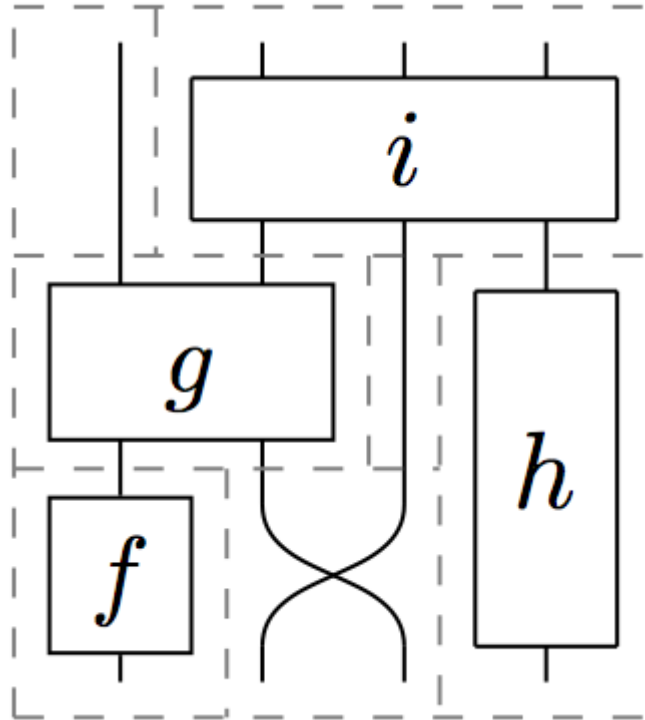

– *circuits* –

Defn. ... := can be build with \otimes and \circ .

– *circuits* –

Defn. ... := can be build with \otimes and \circ .

Fact. ...are boring.

– string diagrams –

*When two systems, of which we know the states by their respective representatives, enter into temporary physical interaction due to known forces between them, and when after a time of mutual influence the systems separate again, then they can no longer be described in the same way as before, viz. by endowing each of them with a representative of its own. **I would not call that one but rather the characteristic trait of quantum mechanics**, the one that enforces its entire departure from classical lines of thought.*

— Erwin Schrödinger, 1935.

– string diagrams –

1. ‘Circuits’ with **cup-state** and **cup-effect**:

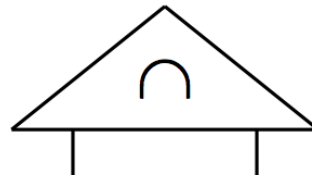
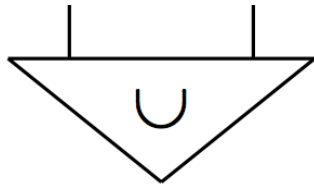

which satisfy:

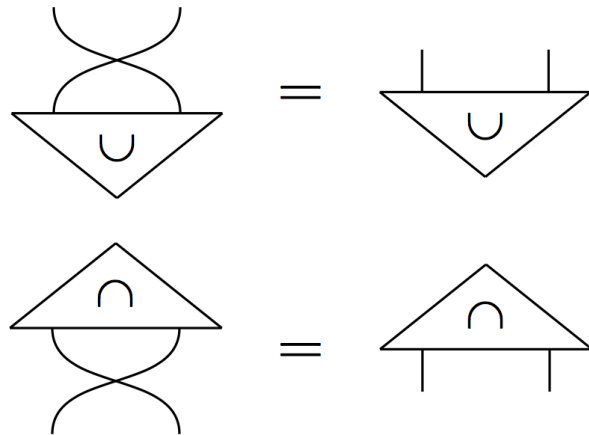
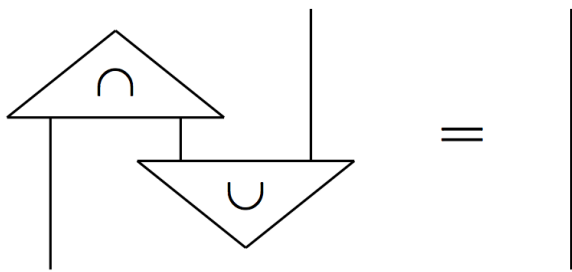

– string diagrams –

2. diagrams allowing in-in, out-out and out-in wiring:

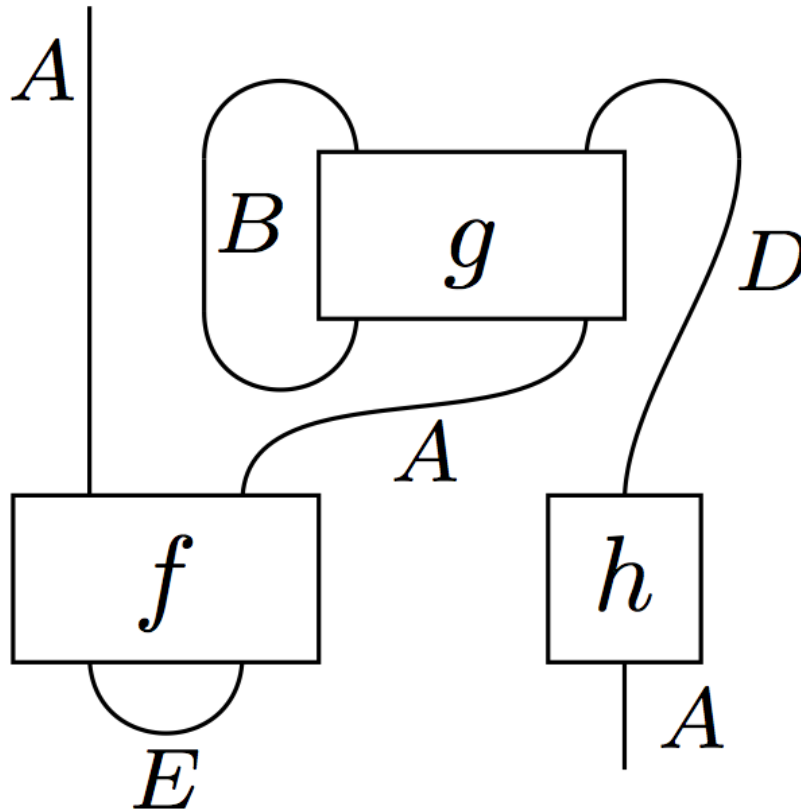

– string diagrams –

From **1.** to **2.**:

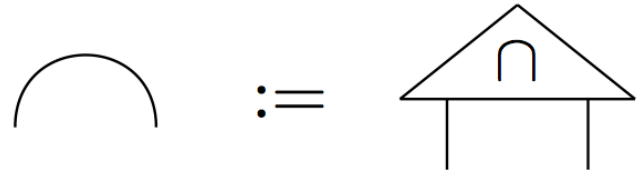
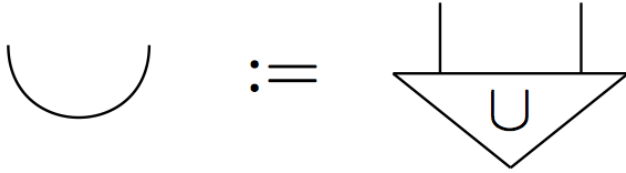

so that:

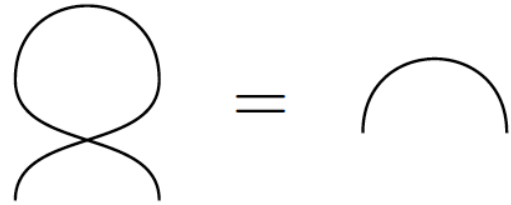
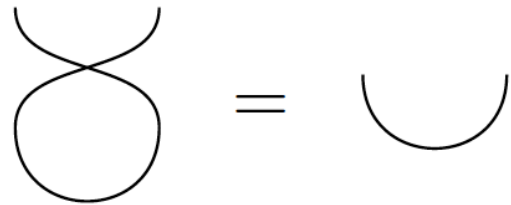
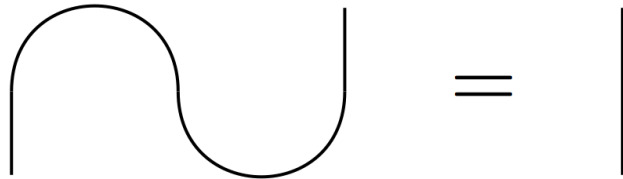

– string diagrams –

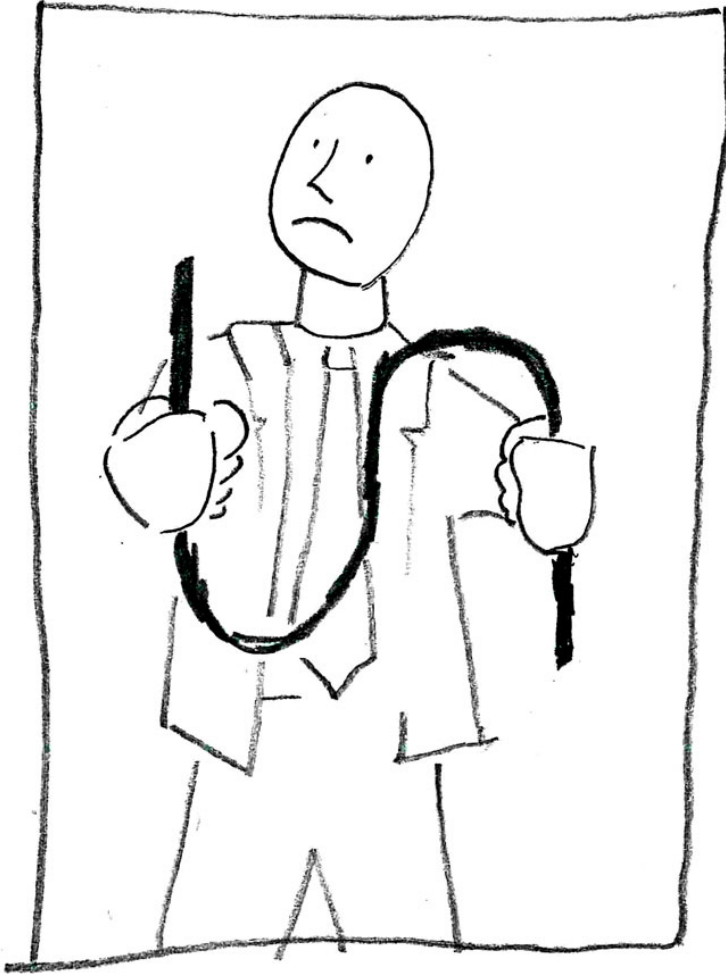

– tautology –

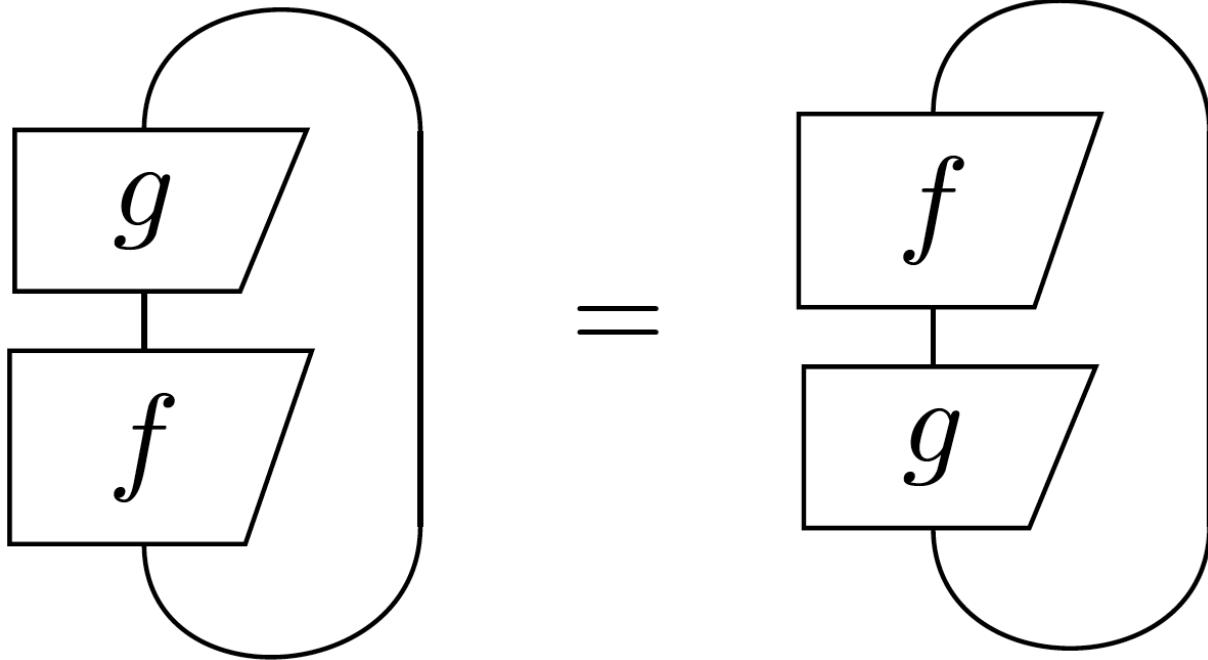

– *implicit diagrammatic notion* –

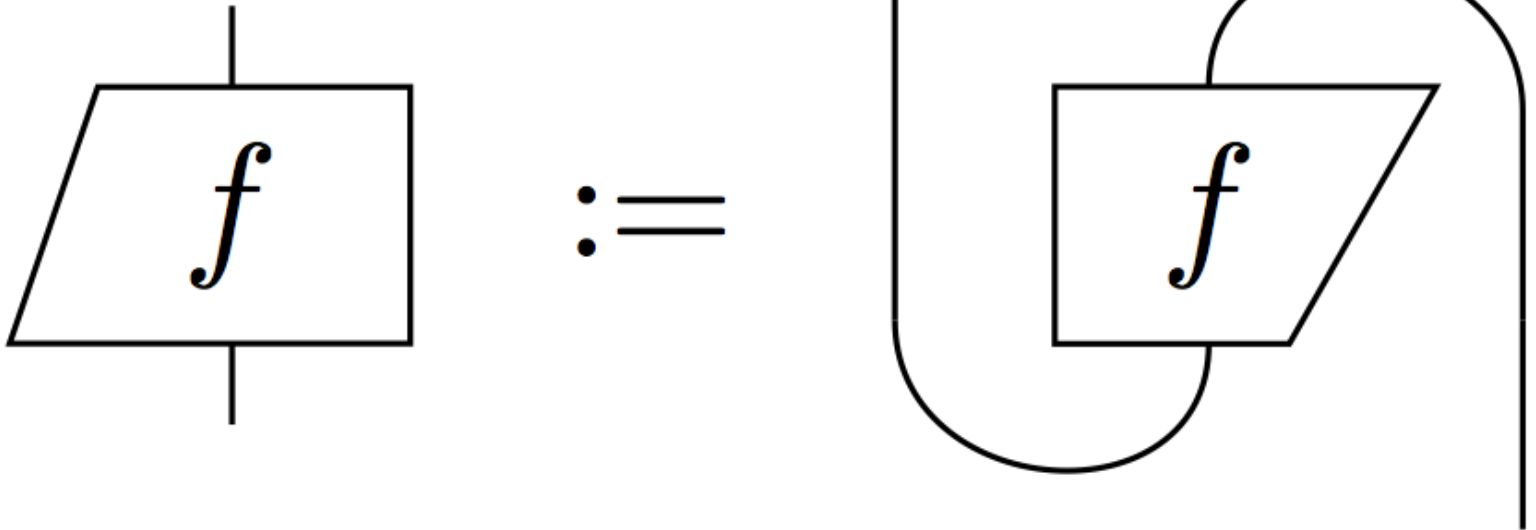

– implicit diagrammatic notion –

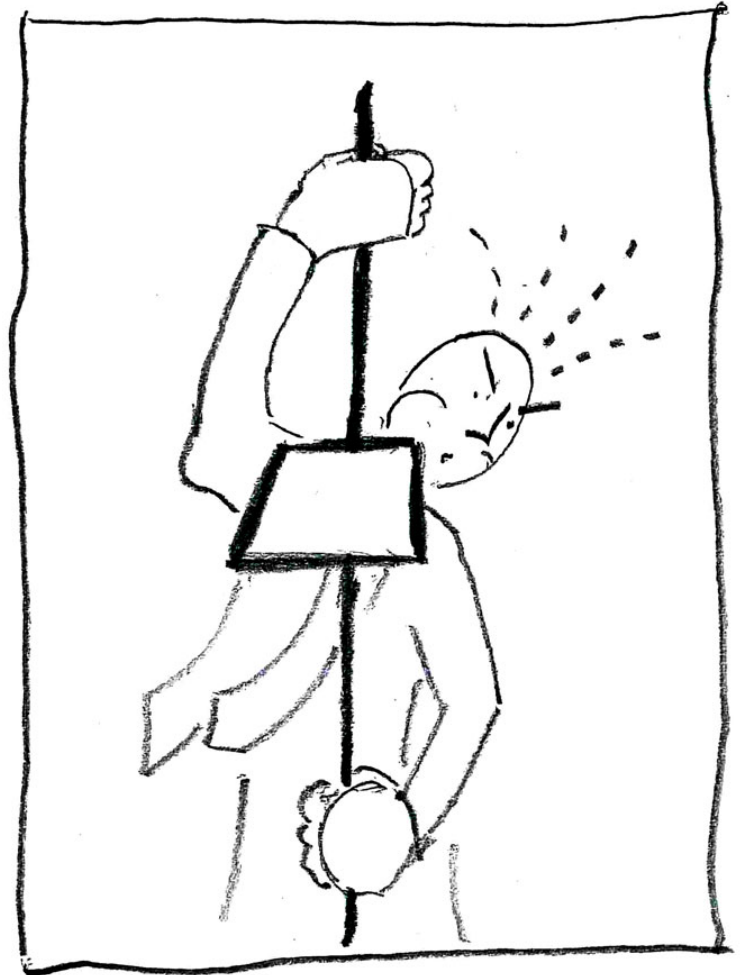
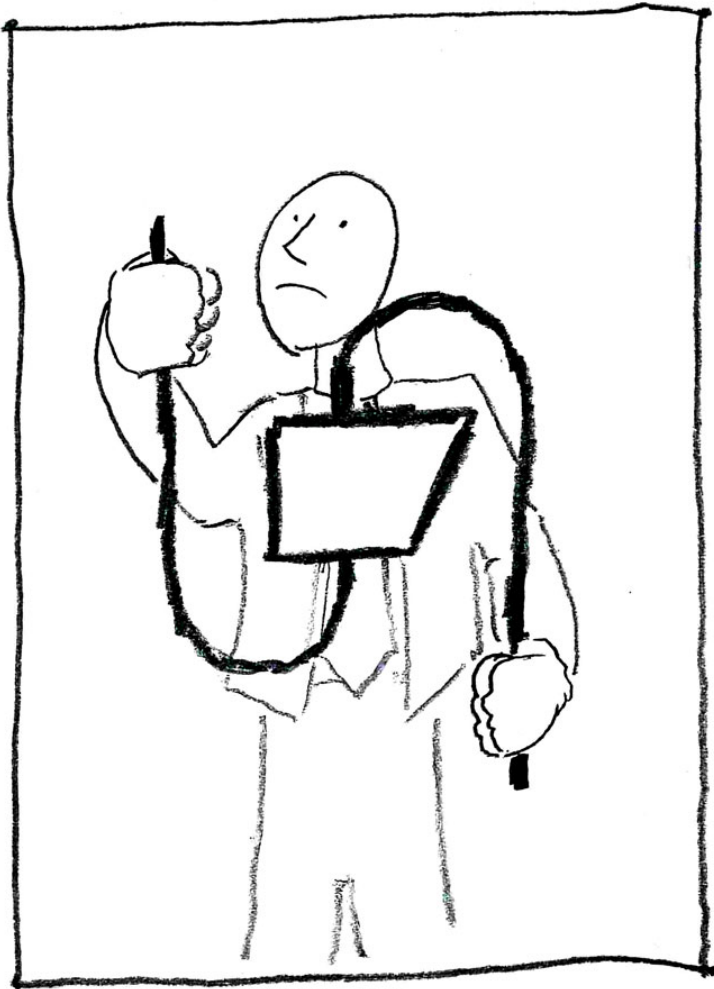

– quantum teleportation –

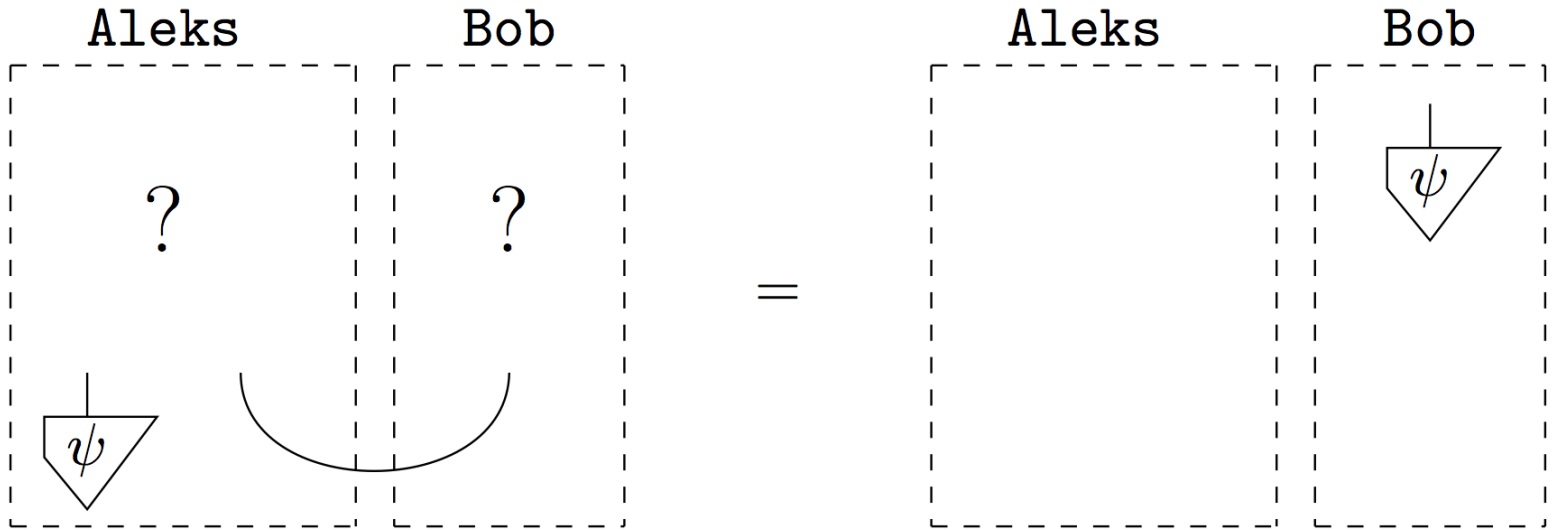

– quantum teleportation –

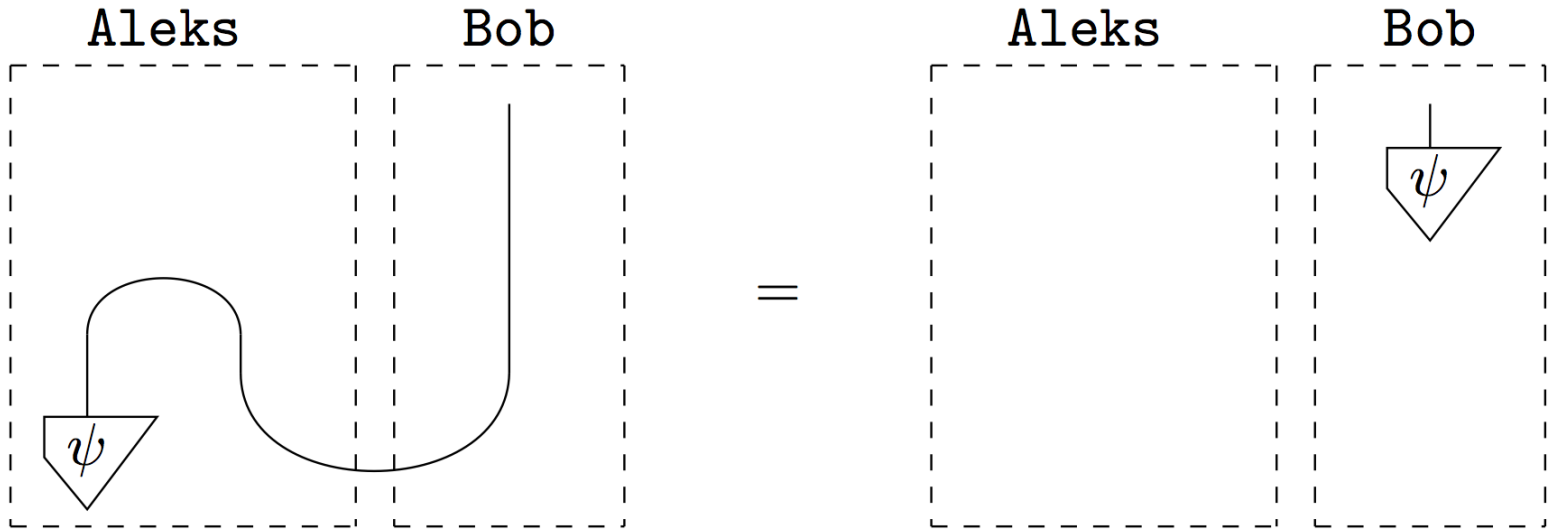

– quantum teleportation –

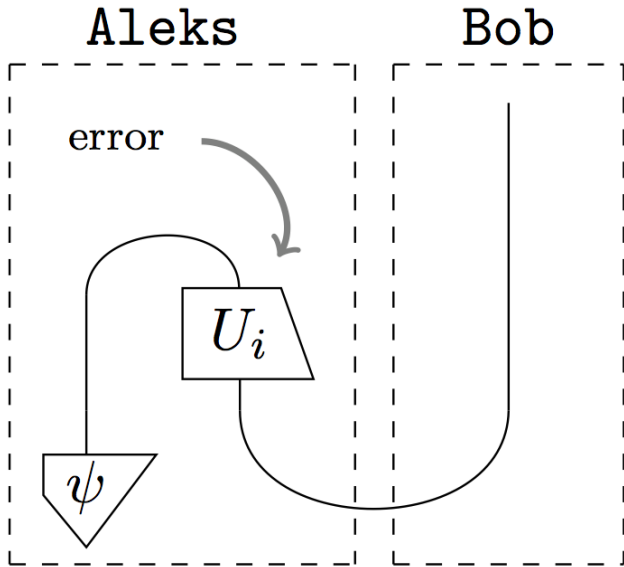

=

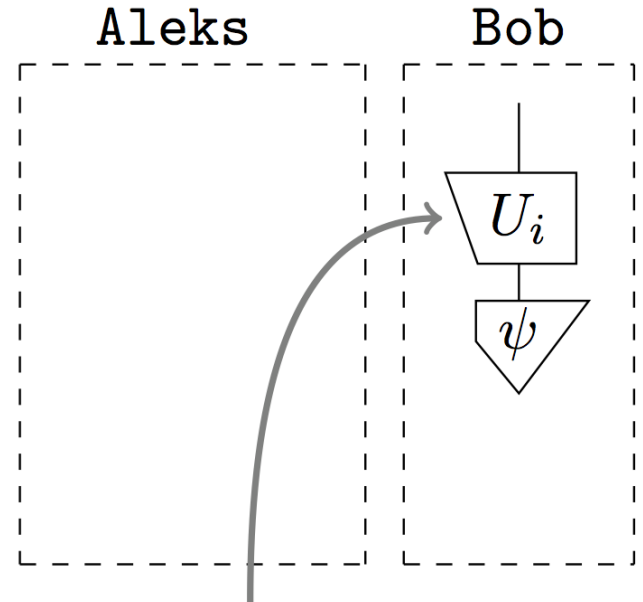

Bob's problem now!

– adjoint & conjugate –

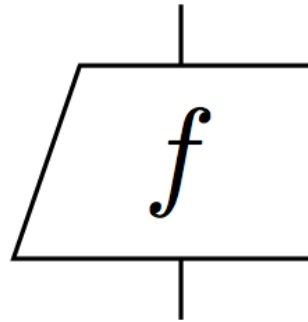
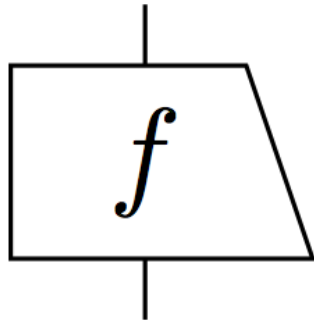
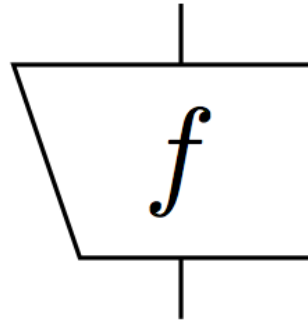
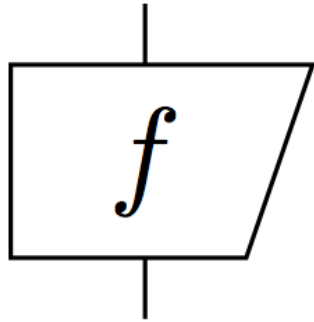

– isometry (& unitarity) –

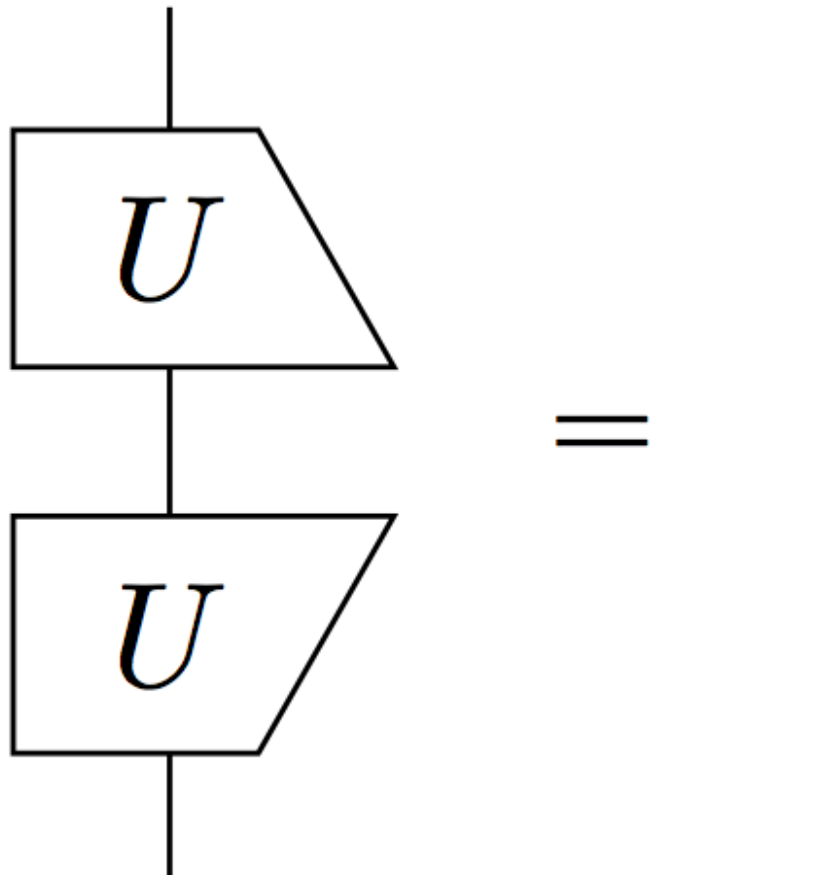

– quantum teleportation –

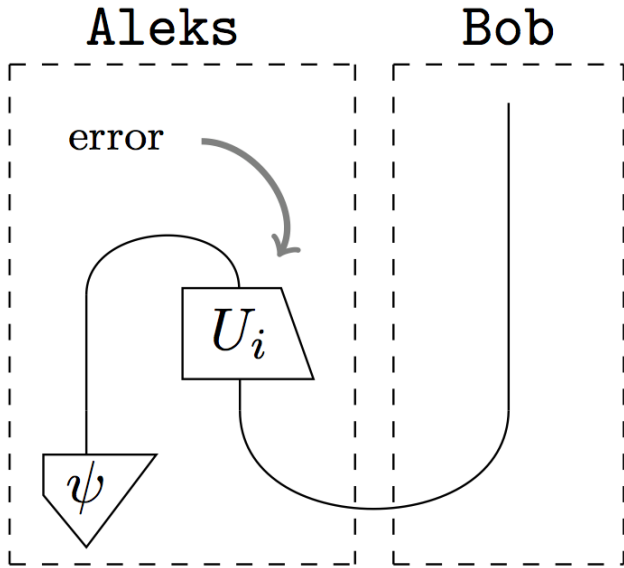

=

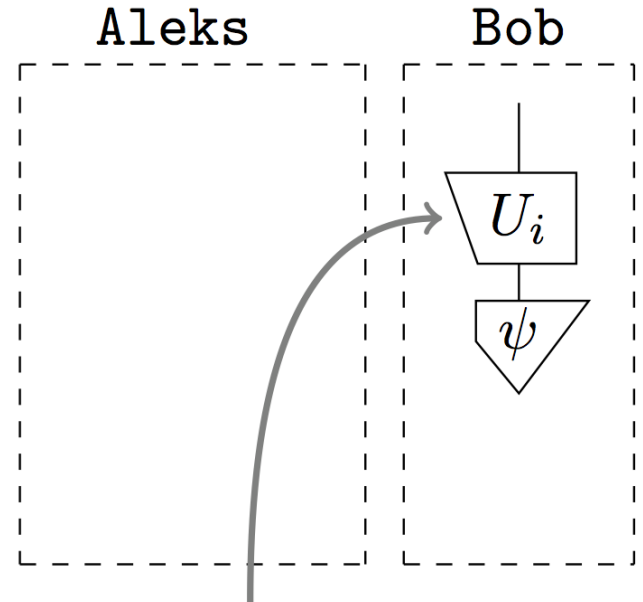

Bob's problem now!

– quantum teleportation –

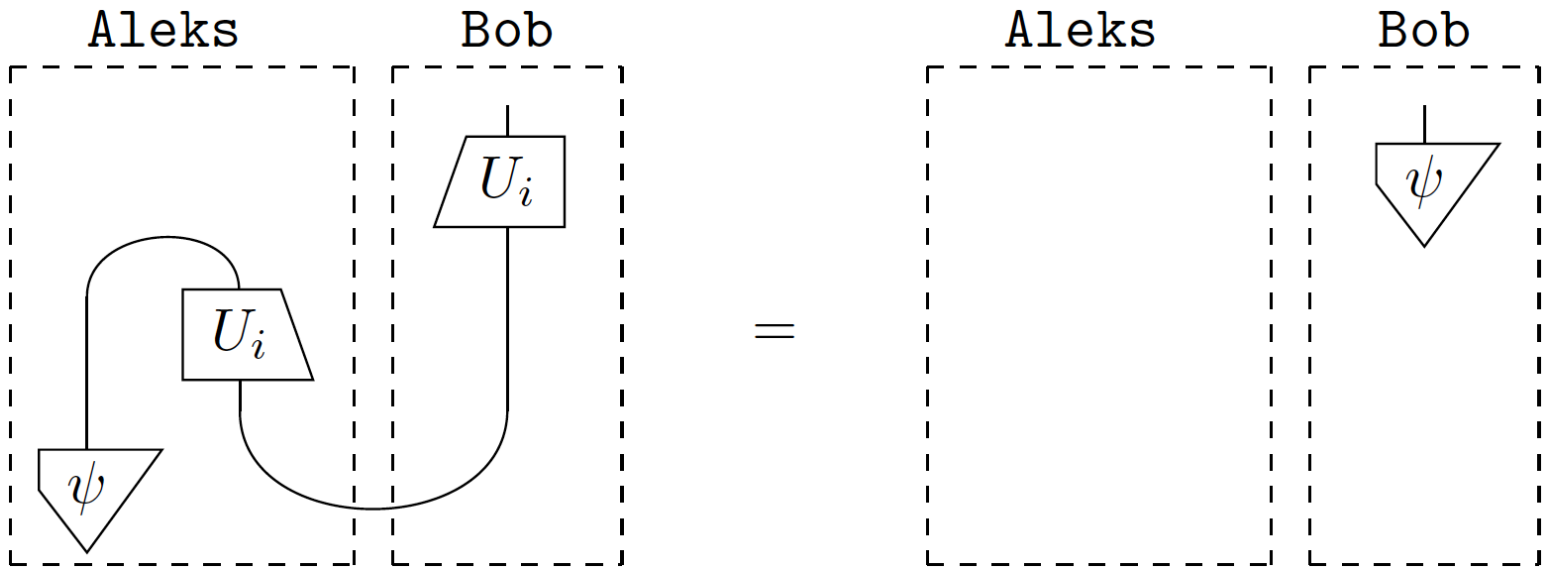

– SMCs as diagrams –

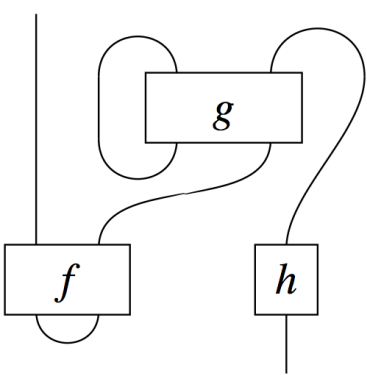
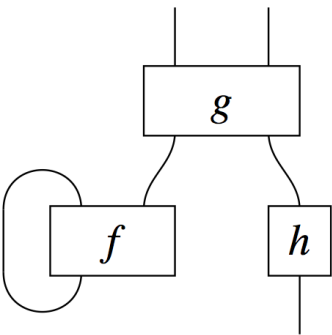
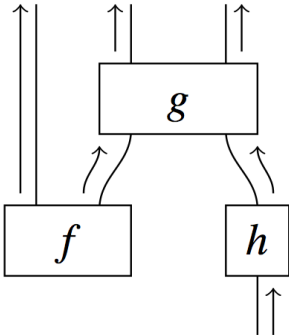
compact closed	traced	boring plain ones
		
<p>string diagrams</p> <p>no ins/outs</p>	<p>diagrams</p> <p>outs to ins</p>	<p>circuits</p> <p>causal structure</p>

– *completeness* –

THM. (Selinger, 2008)

An equation between string diagrams holds, if and only if it holds for Hilbert spaces and linear maps.

– *completeness* –

THM. (Selinger, 2008)

An equation between string diagrams holds, if and only if it holds for Hilbert spaces and linear maps.

I.e. defining Hilbert spaces and linear maps ‘from diagrams’ is a conservative extension of string diagrams.

– *completeness* –

THM. (Selinger, 2008)

An equation between string diagrams holds, if and only if it holds for Hilbert spaces and linear maps.

I.e. defining Hilbert spaces and linear maps ‘from diagrams’ is a conservative extension of string diagrams.

Since last summer, we have:

UNIVERSAL COMPLETENESS!



– *completeness* –

THM. (Selinger, 2008)

An equation between string diagrams holds, if and only if it holds for Hilbert spaces and linear maps.

I.e. defining Hilbert spaces and linear maps ‘from diagrams’ is a conservative extension of string diagrams.

Since last summer, we have:

UNIVERSAL COMPLETENESS!



(see three papers at LiCS this year on ZX-calculus)

– *quantum vs. classical* –

$$\frac{\text{classical system}}{\text{quantum system}} = \frac{\text{single wire}}{\text{double wire}}$$

– pure quantum process –

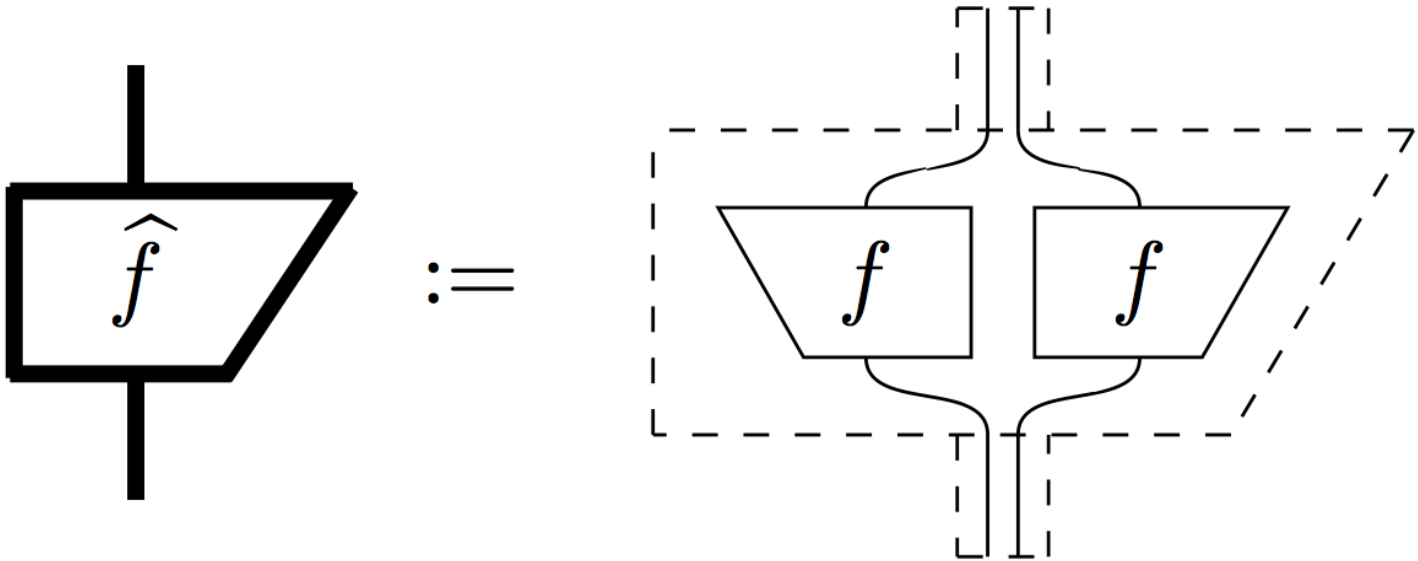

– Born-rule –

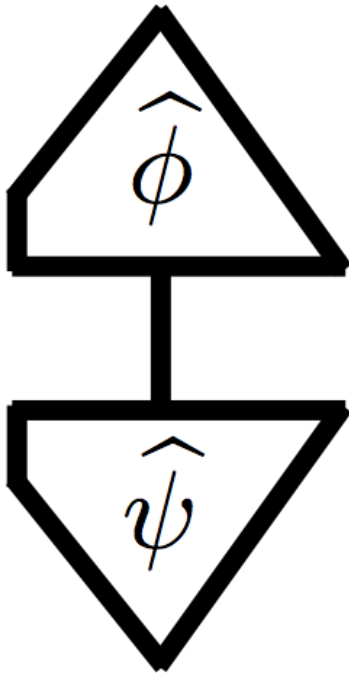

\equiv

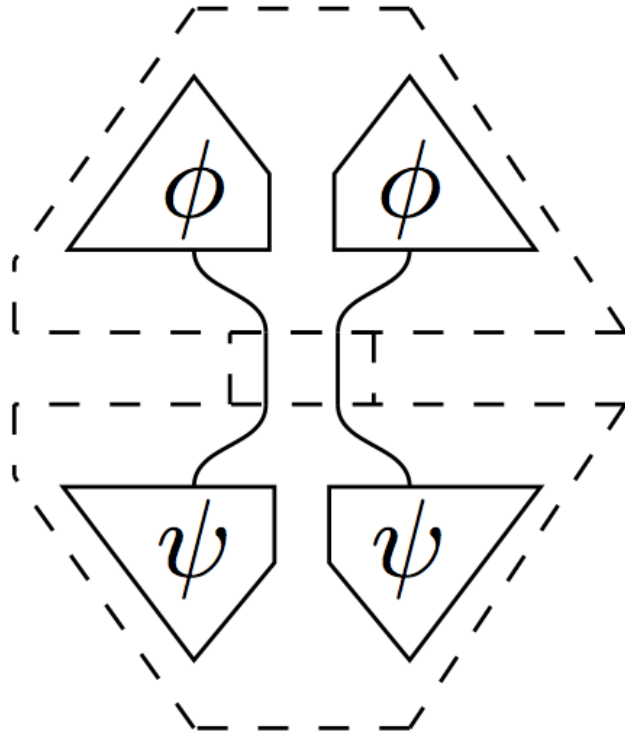

\equiv

– *discarding* –

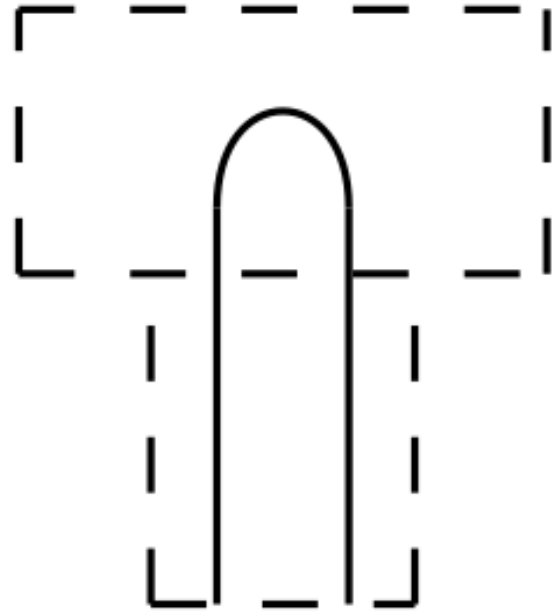
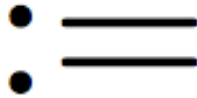
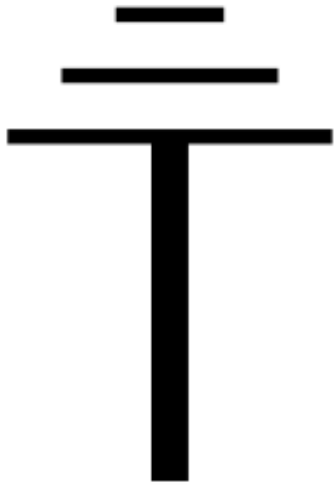

– mixed quantum process –

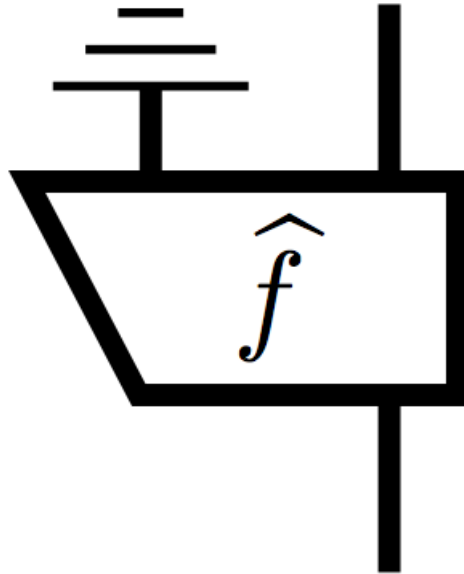

– mixed quantum process –

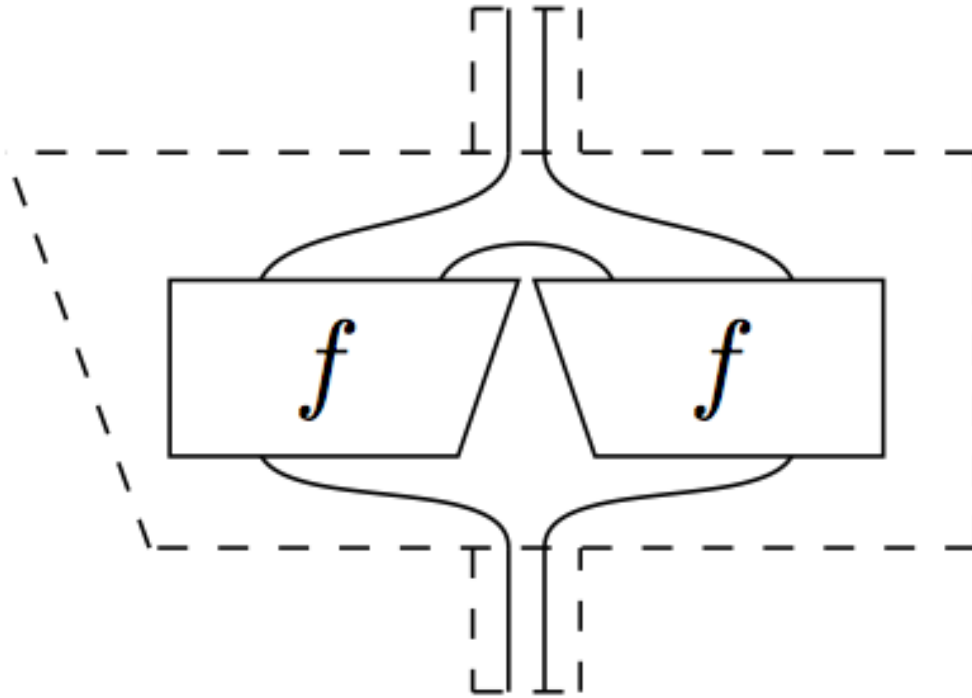

– causality –

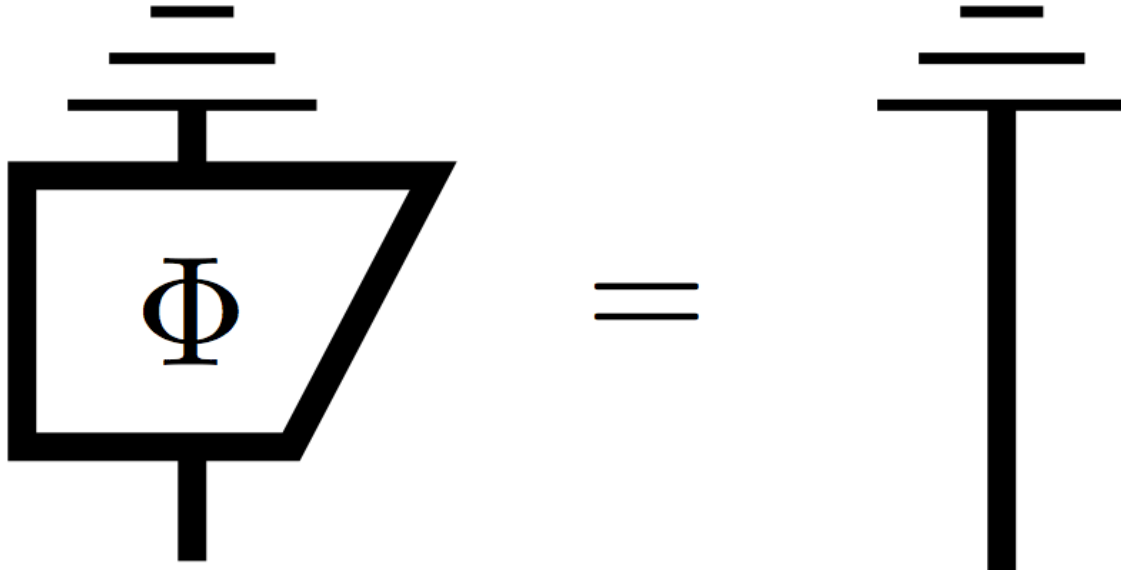

– causality –

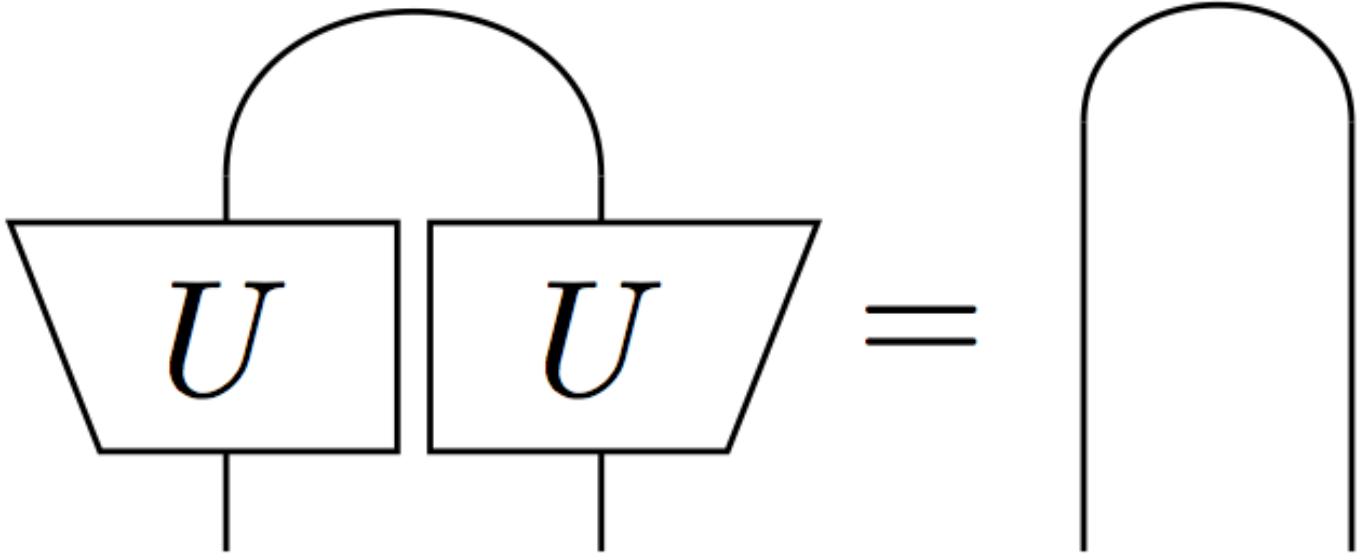

– causality –

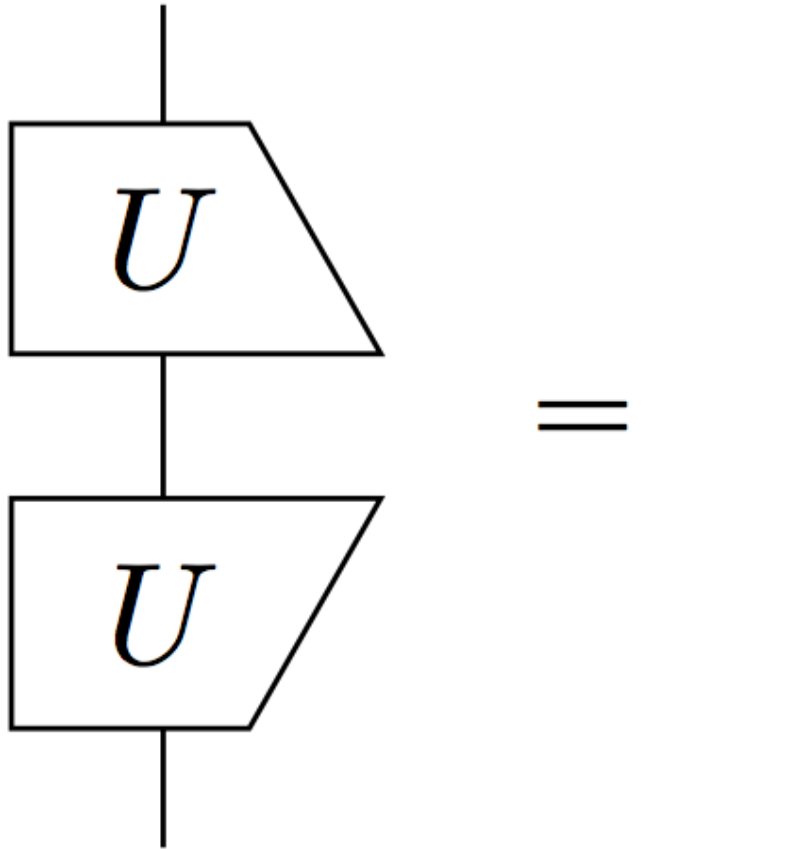

— spiders —

Damn it! I knew she was a monster!
John! Amy! Listen! Guard your buttoholes.

— David Wong, *This Book Is Full of Spiders*, 2012.

– spiders –

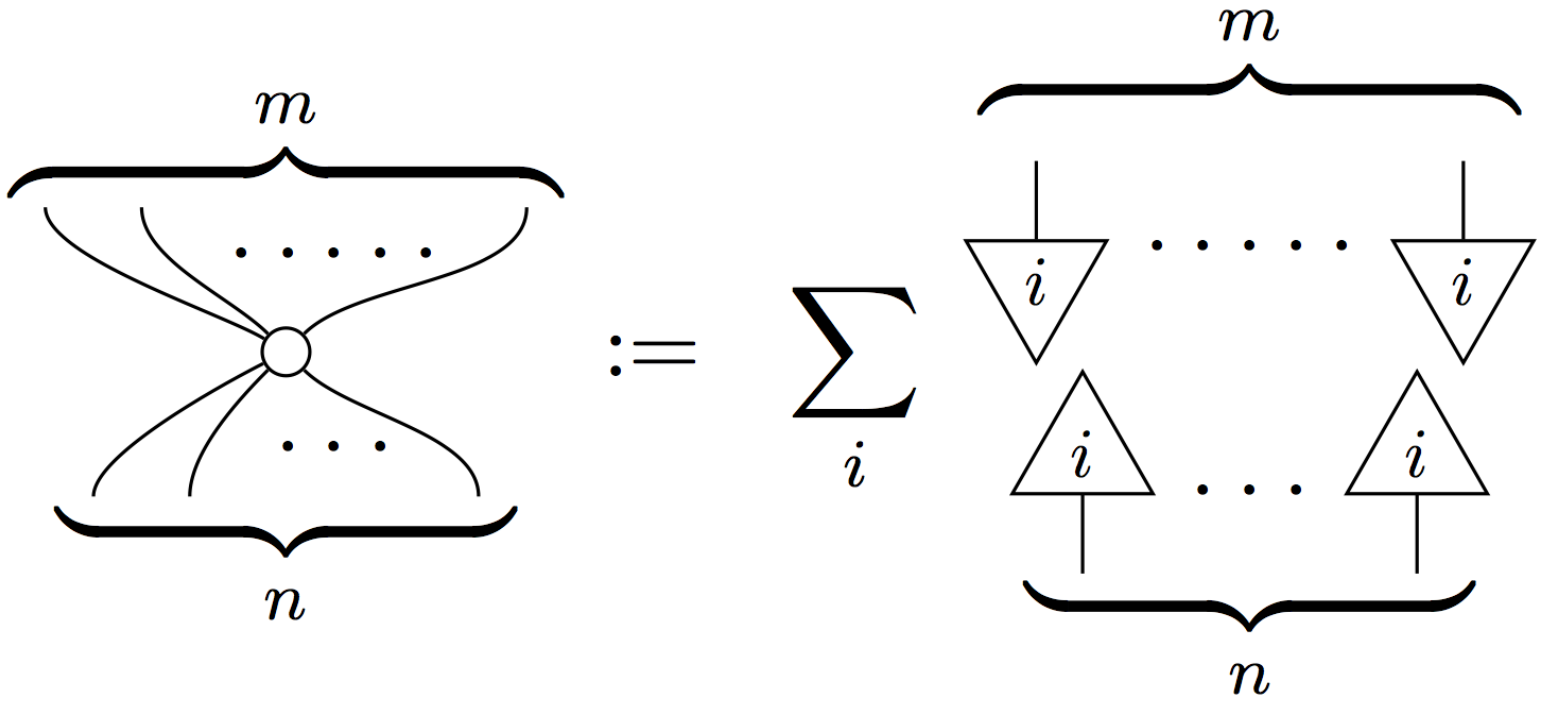

– spiders –

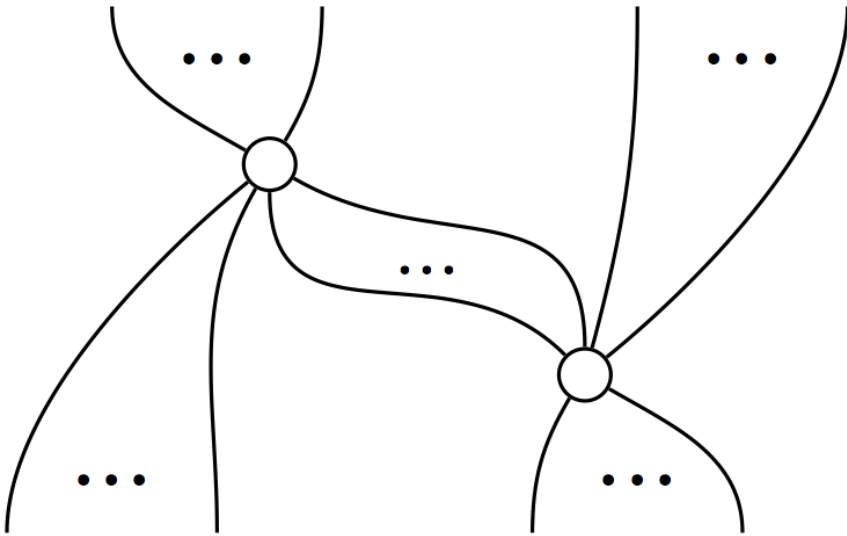

=

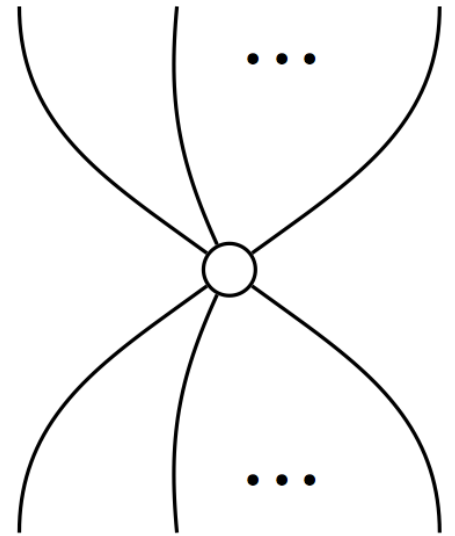

– spiders –

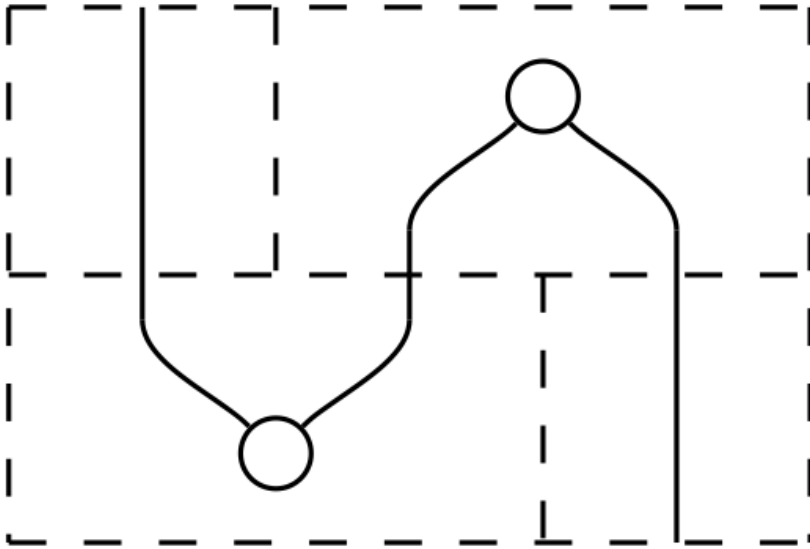

=



– spiders –

copy :=

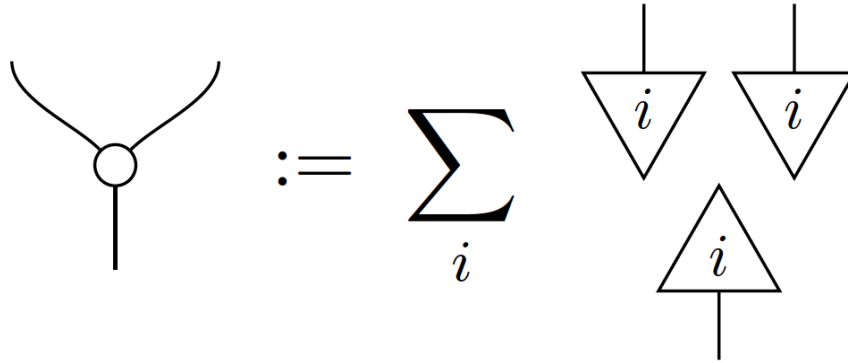

delete :=

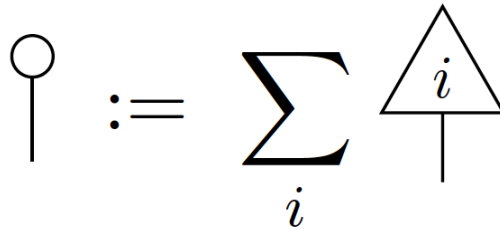

– spiders –

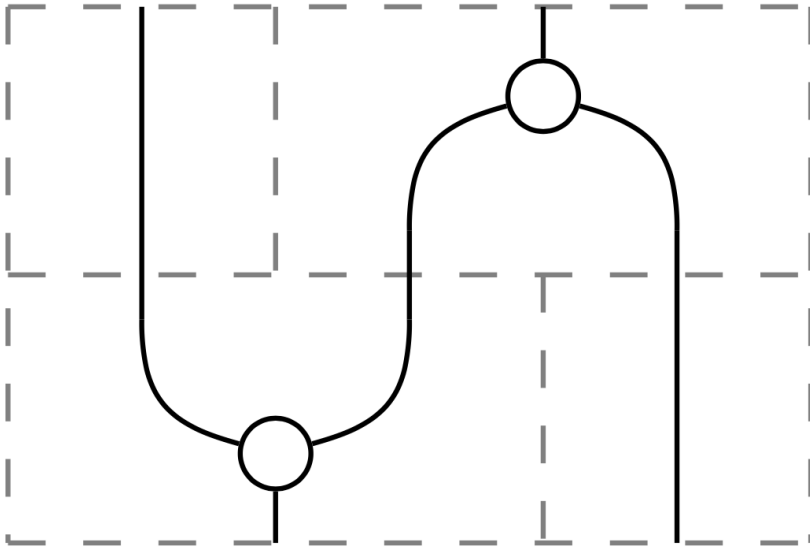

=

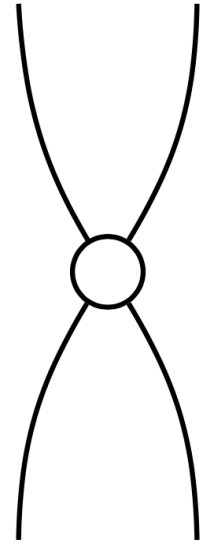



– spiders –

THM 1. spiders \equiv dag. spec. comm. Frob. algs

– spiders –

THM 1. spiders \equiv dag. spec. comm. Frob. algs

THM 2. FHilb: dag. spec. comm. Frob. algs \equiv ONBs

– spiders –

encode :=

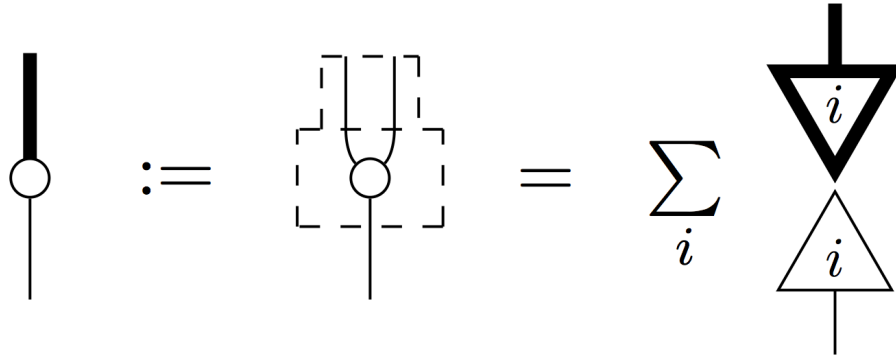

measure :=

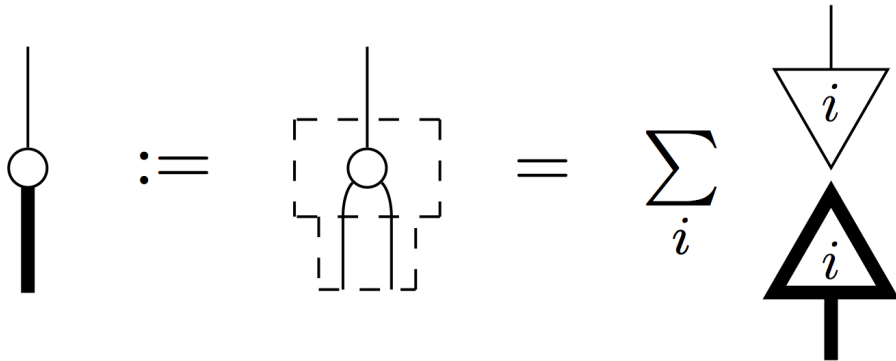

– spiders –

controlled isometry :=

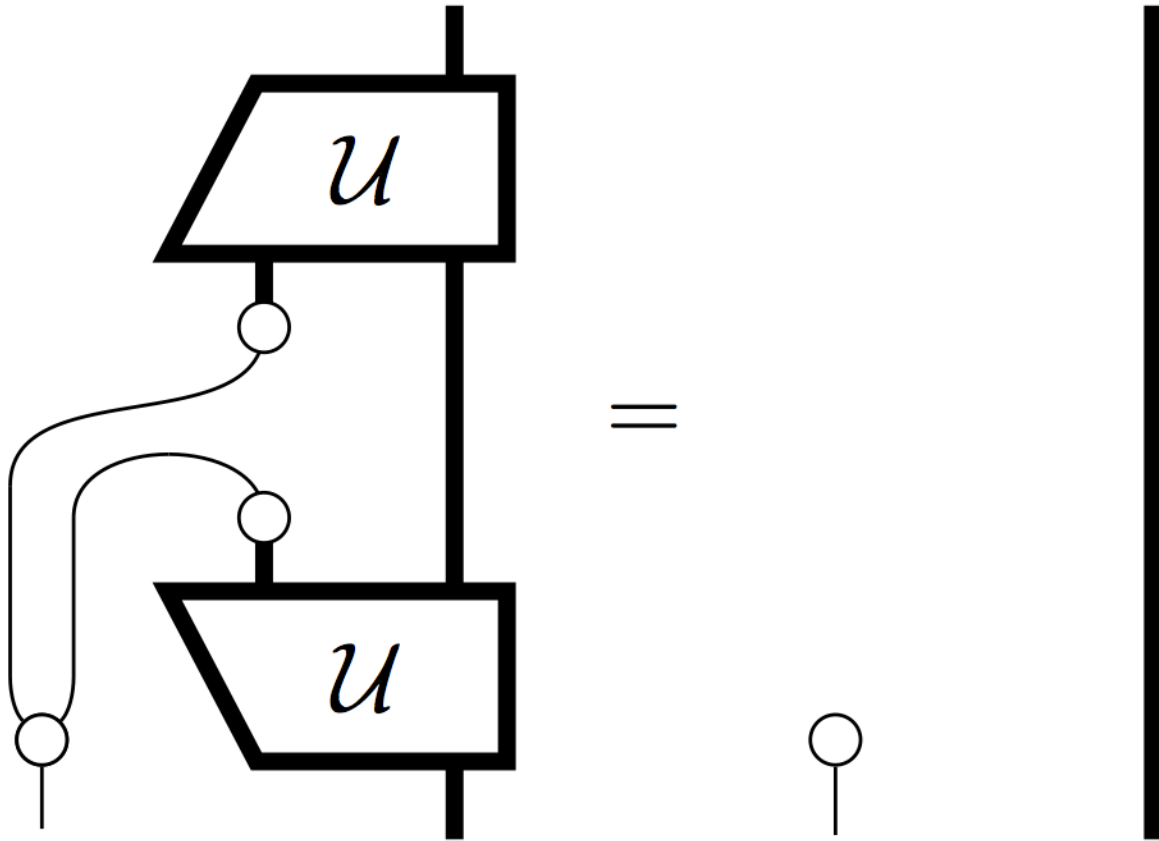

— teleportation with phone call —

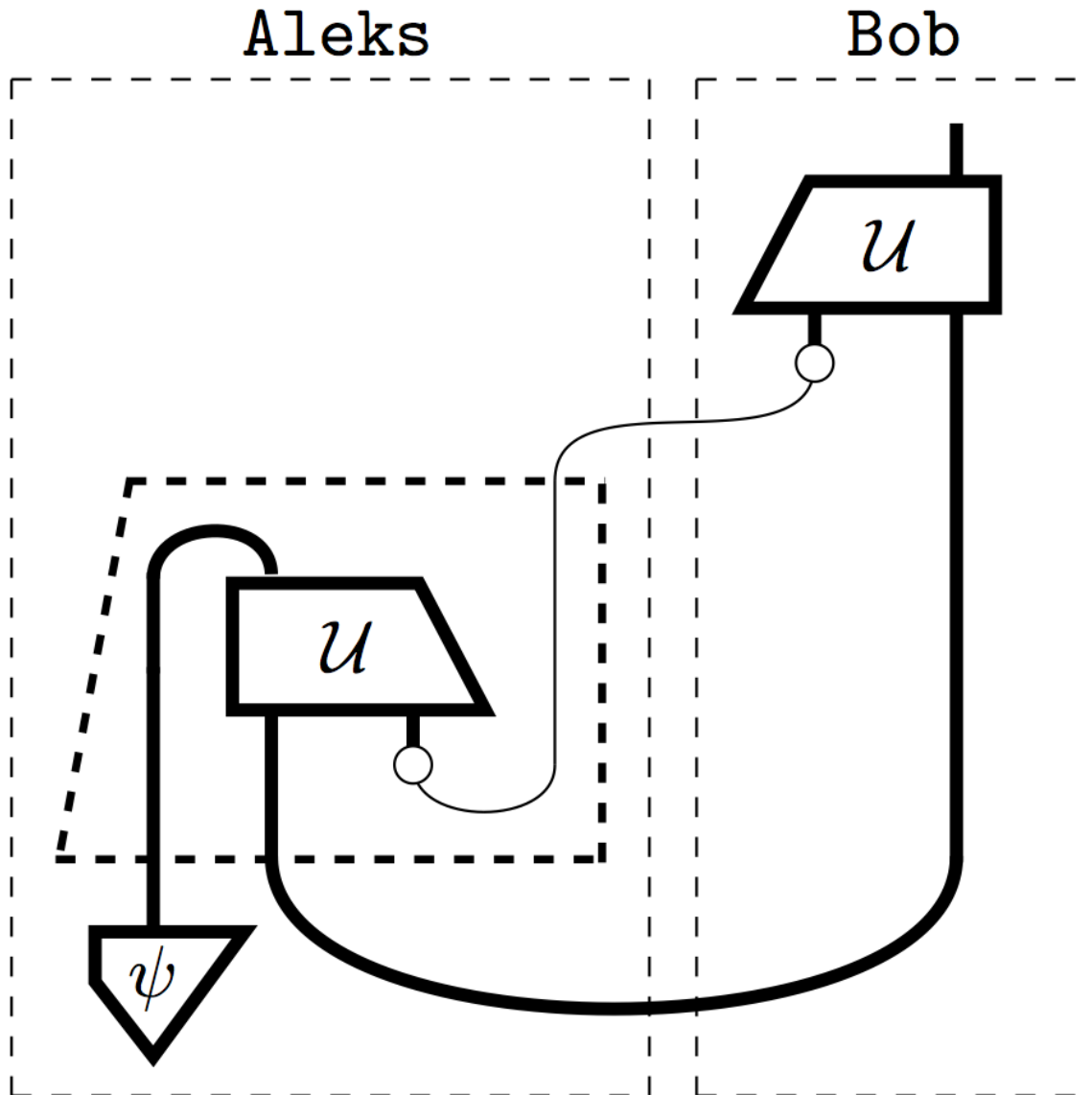

— teleportation with phone call —

Aleks

Bob

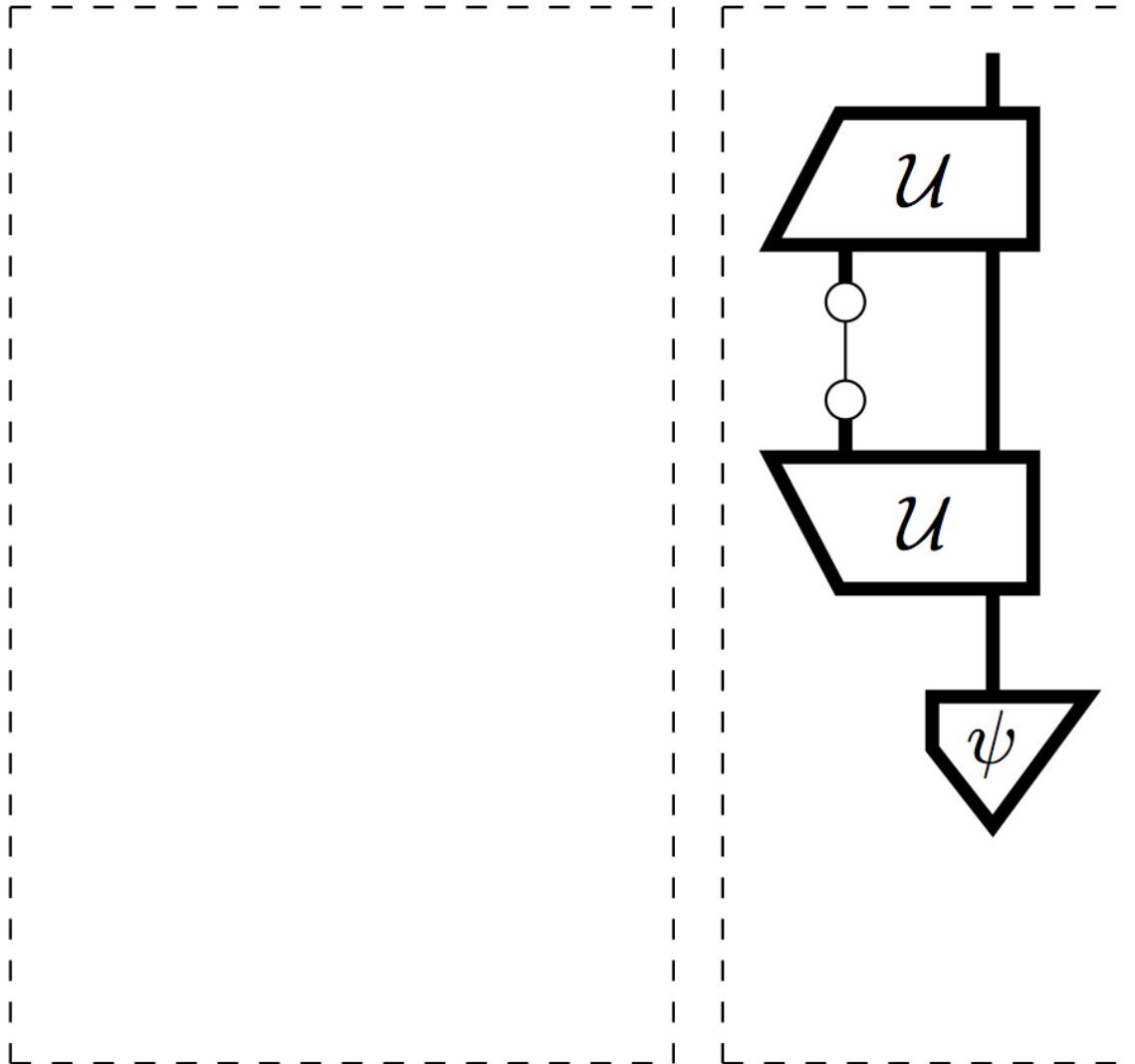

— teleportation with phone call —

Aleks

Bob

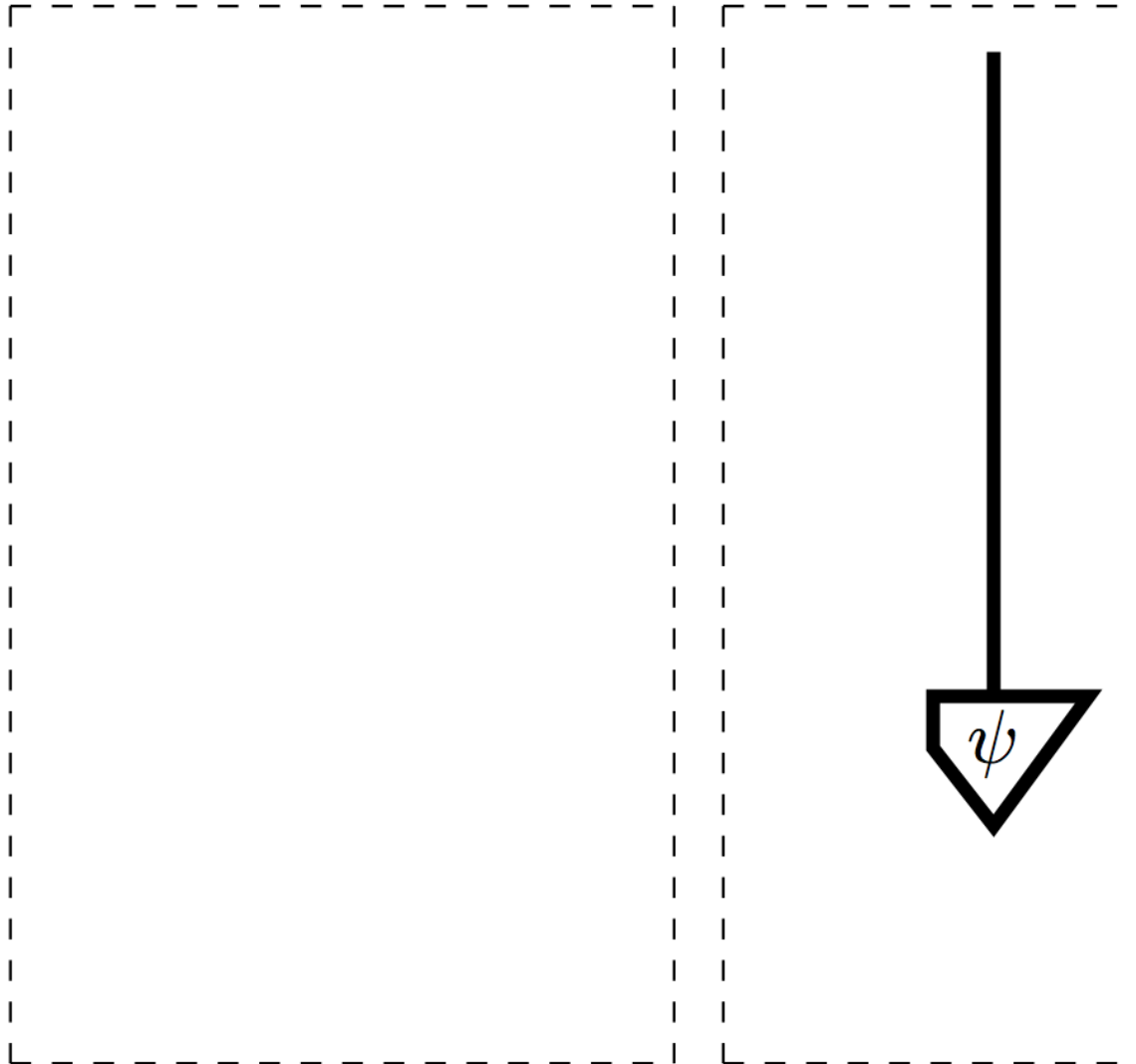

— structural evolution

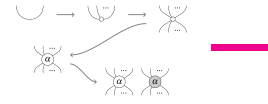

— structural evolution

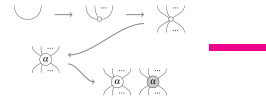

— structural evolution —

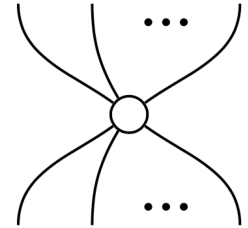
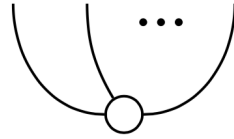
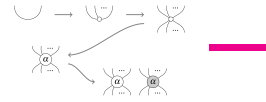

— structural evolution —

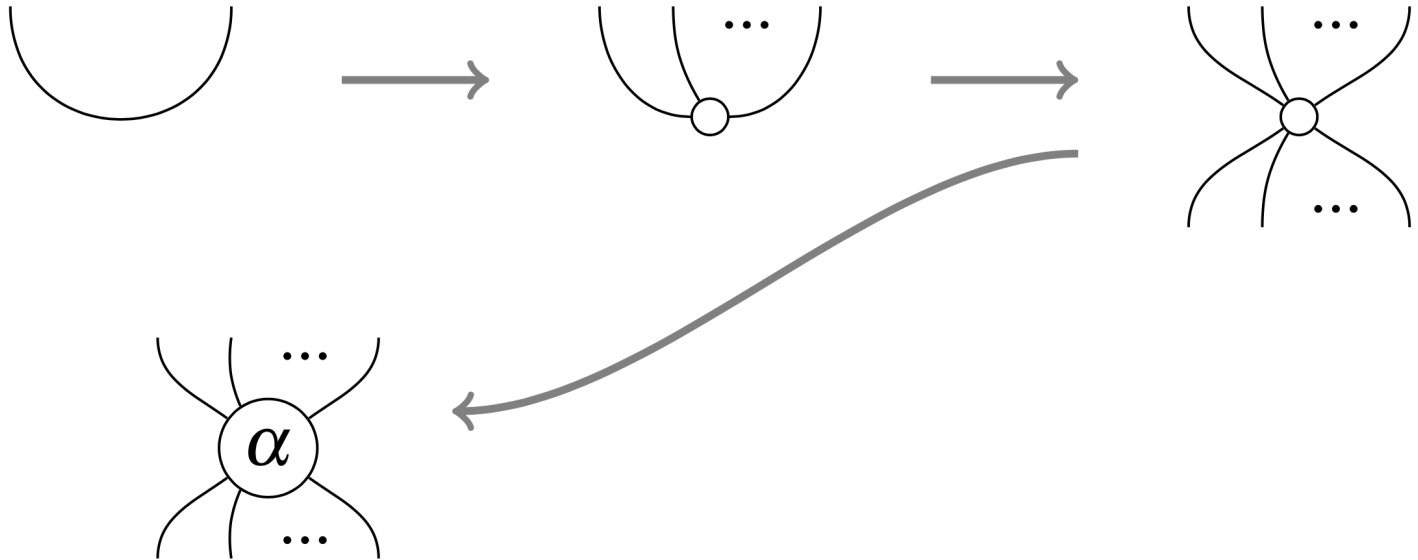
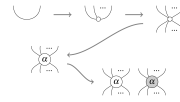

— structural evolution —

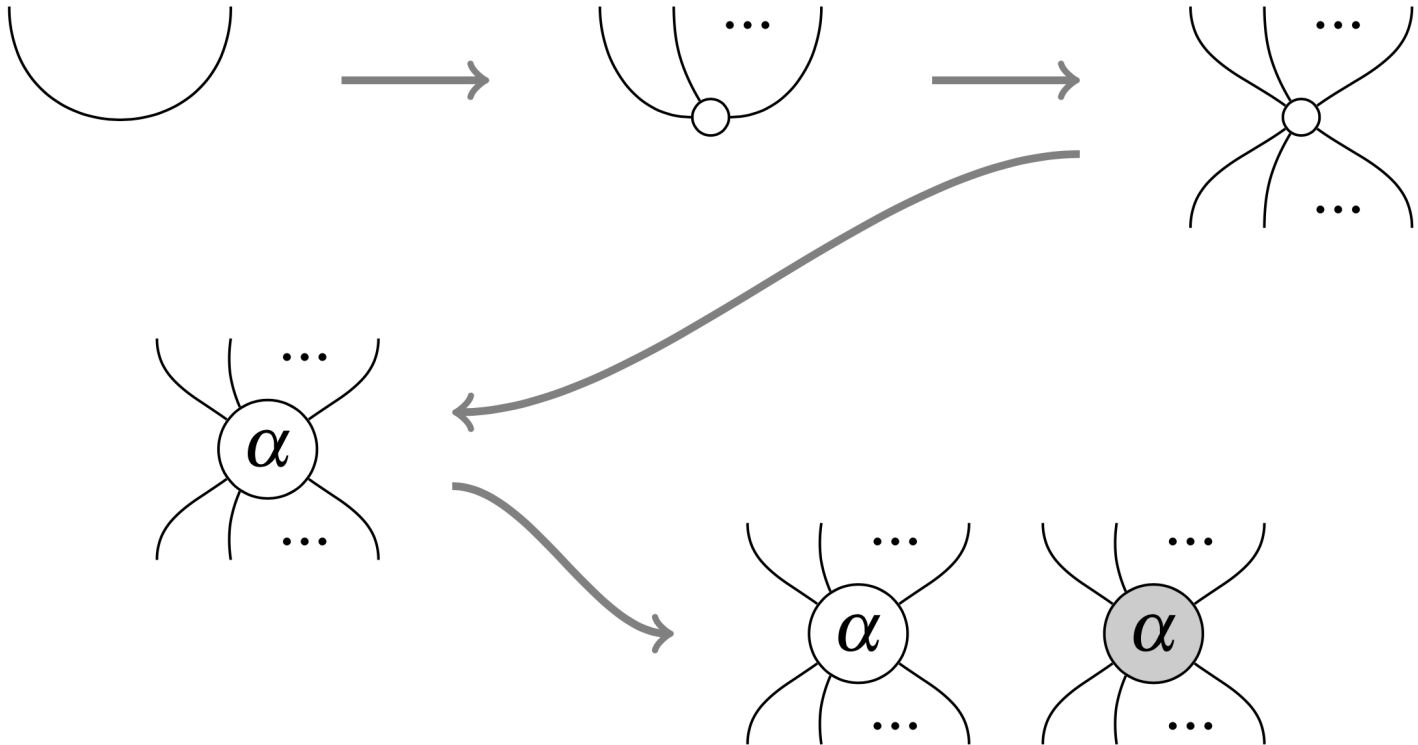
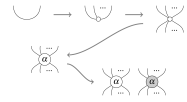

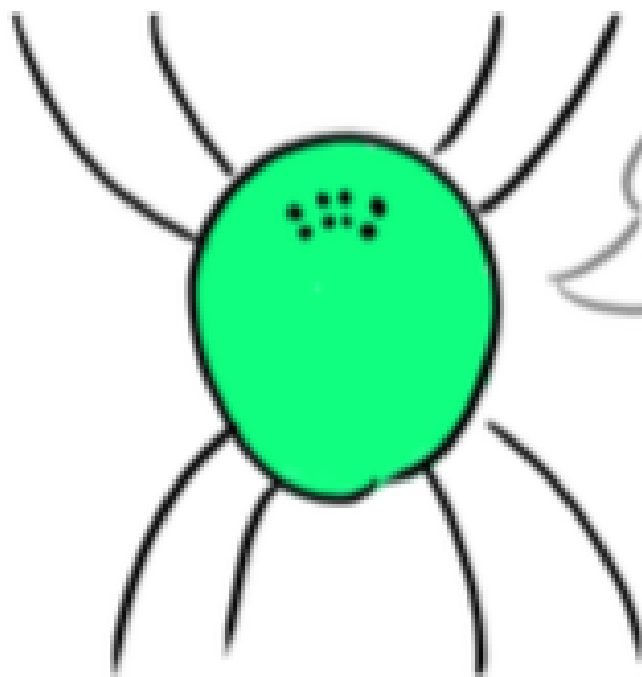

Hi!
I'm a
Spider!

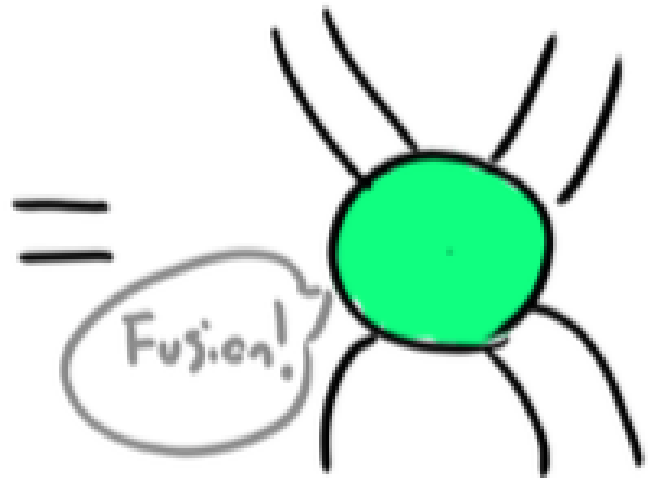
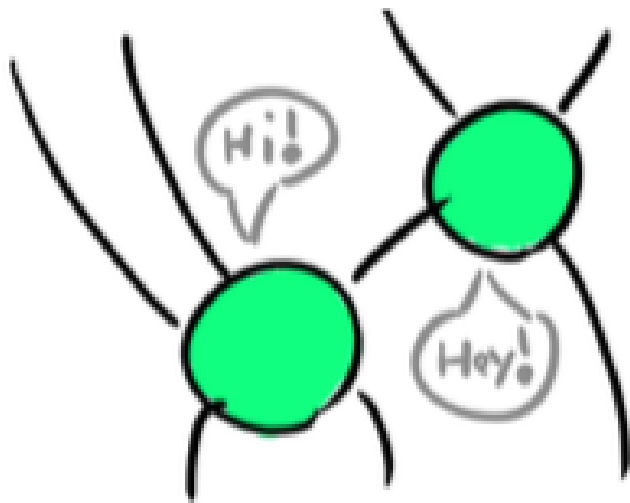

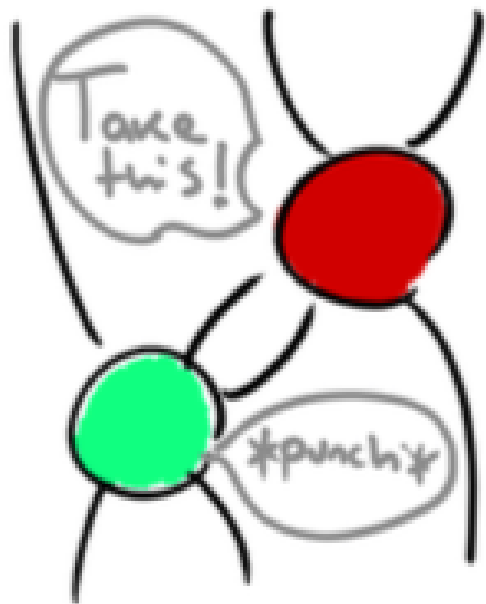

=



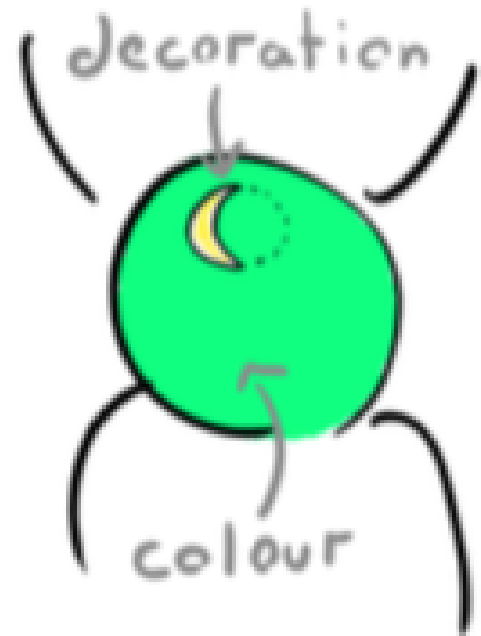
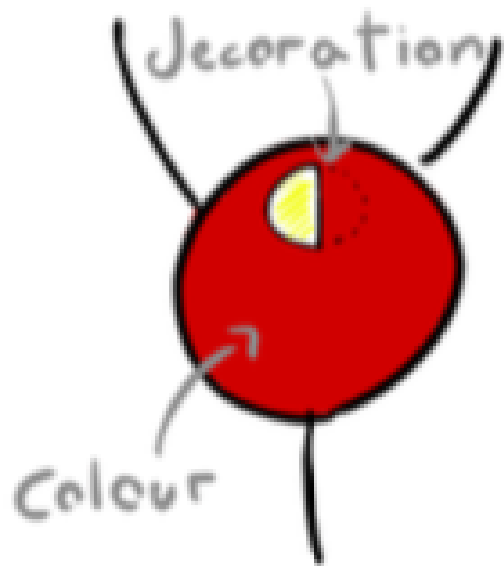

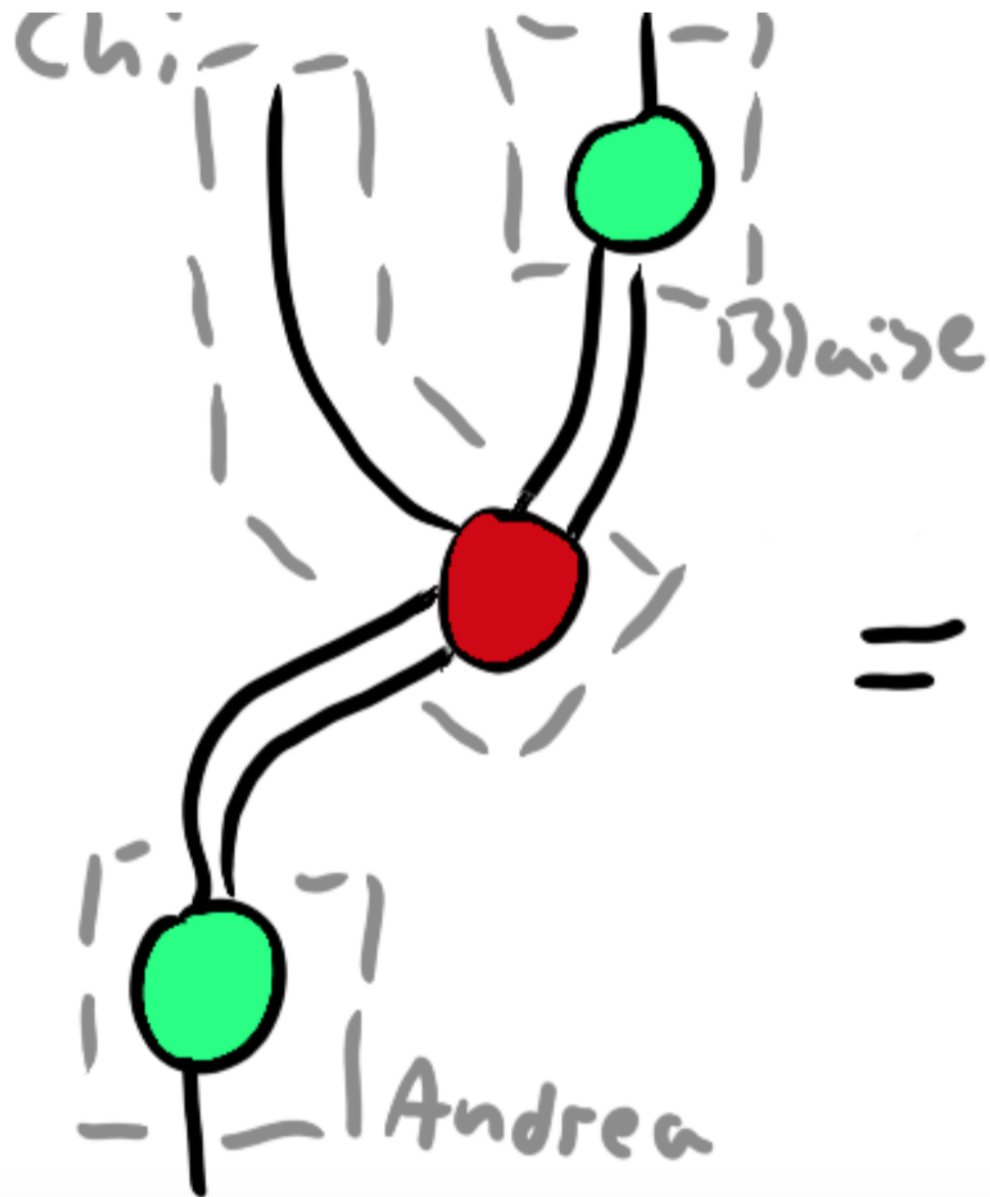

=



Any age restrictions?

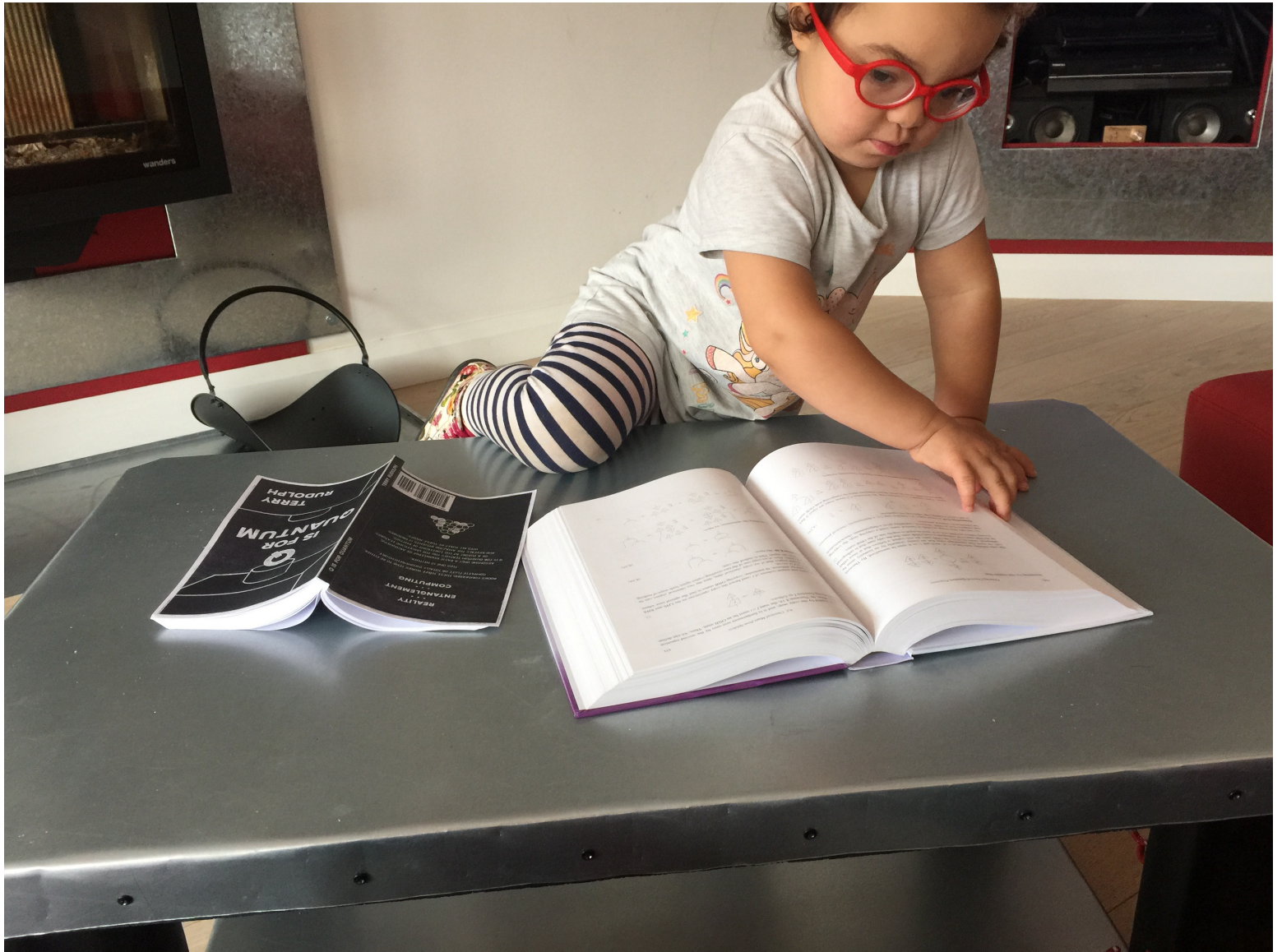

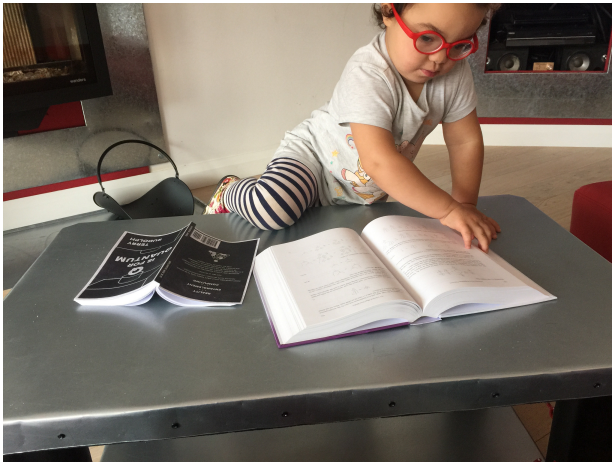

KIDS OUTPERFORM OXFORD STUDENTS AND DISCOVER QUANTUM FEATURES THAT TOOK TOP SCIENTISTS 60y



Bob & Stefano:

- Two Tutorials

Bob, Selma & Stefano:

- Detailed experimental design

Carmen Const., Dan Ghica, Ioannis Raptis & Harny W.:

- Provision of schools and kids initially

Bob, Dan Marsden & Selma:

- Follow-up Leverhulme proposal

"Picturing Quantum Processes is a lively and refreshing romp through the author's diagrammatic and categorical approach to quantum processes. I recommend this book with no lower age limit required!"
Clark Kaufman, University of Illinois

"This book develops from scratch the category theoretic and diagrammatic language for quantum theory especially quantum processes. It is a remarkable achievement: rigorous, crystal-clear, complete and a delight to read."
Jeremy Butterfield, University of Cambridge

The unique features of the quantum world are explained in this book through the language of diagrams, setting out an innovative visual method for presenting complex theories. Requiring only basic mathematical literacy this book employs a unique formalism that builds an intuitive understanding of quantum features while eliminating the need for complex calculations. This actively diagrammatic presentation of quantum theory represents the culmination of 10 years of research, uniting classical techniques in linear algebra and Hilbert spaces with cutting-edge developments in quantum computation and foundations.

Written in an entertaining and user-friendly style and including more than 100 exercises, this book is an ideal first course in quantum theory, foundations, and computation for students from undergraduate to PhD level, as well as an opportunity for researchers from a broad range of fields, from physics to biology, linguistics, and cognitive science, to discover a new way of looking at quantum processes and interaction.

Bob Coecke is Professor of Quantum Foundations, Logic and Structures at Oxford University, where he also heads the multi-disciplinary Quantum Mechanics to the Computational Structure of Natural Language meaning and recent interests include causality and cognitive architecture.

Aleks Kissinger is an Assistant Professor of Quantum Structures and Logic at Oxford University. His research focuses on diagrammatic language, rewrite theory, category theory, and applications to quantum computation and the foundations of physics.

CAMBRIDGE
UNIVERSITY PRESS
www.cambridge.org



COECKE
AND
KISSINGER

PICTURING QUANTUM
PROCESSES

CAMBRIDGE

PICTURING QUANTUM
PROCESSES

A First Course in Quantum Theory and Diagrammatic Reasoning

BOB COECKE AND ALEKS KISSINGER



COECKE
AND
KISSINGER

PICTURING QUANTUM
PROCESSES

CAMBRIDGE

PICTURING QUANTUM PROCESSES

A First Course in Quantum Theory and Diagrammatic Reasoning

BOB COECKE AND ALEKS KISSINGER

